

P-15382

S4753

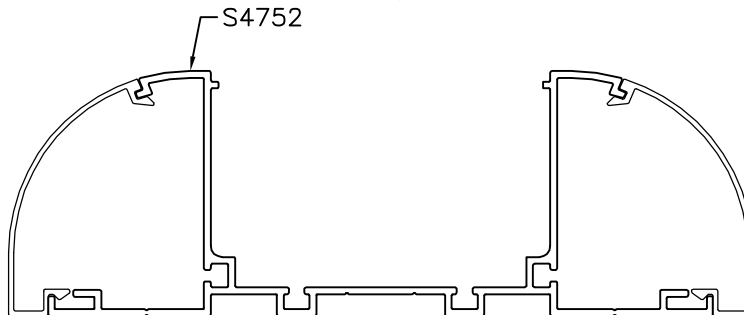
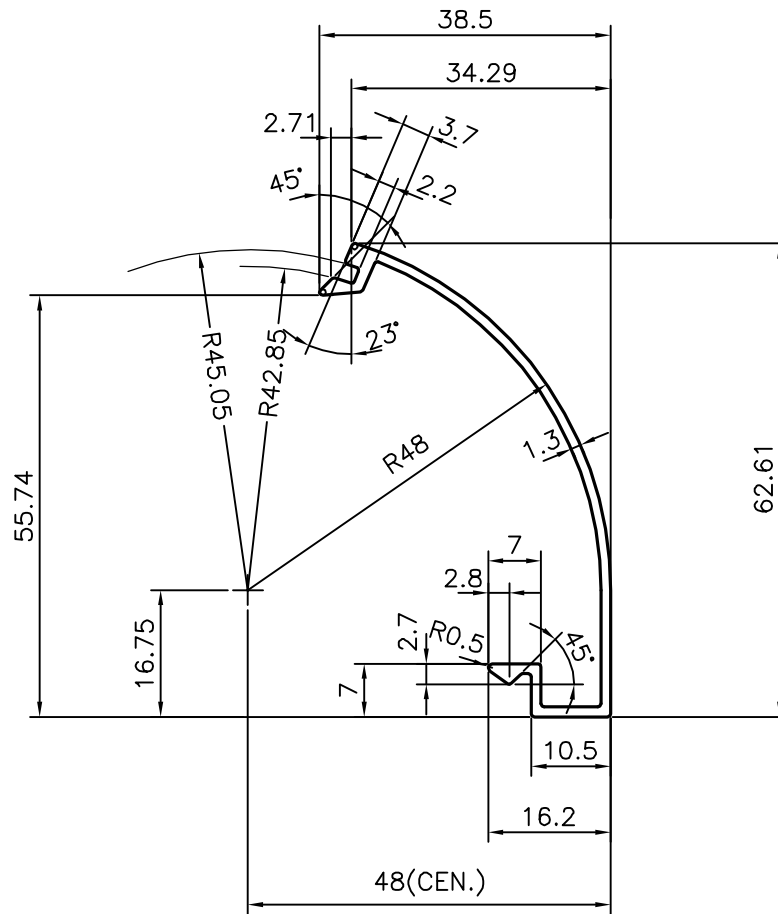

SYMBOL OF QUALITY
AN ISO 9001 COMPANY

JINDAL ALUMINIUM LTD.
BANGALORE-560073 (INDIA)

	NAME	DATE
DRAWN	J.P.KAUSHIK	01-12-2015
CHECKED		
APPROVED	S.S.GARG	05-12-2015
SCALE		1:1
AREA	mm ²	147.4
PERIMETER	mm.	214.986
WEIGHT	kg/m	0.398
DRAWING No.	SECTION No.	
P-15382	-	
S4753	S4753	

1. ALL DIMENSIONS ARE IN mm.
2. ROUND OFF ALL SHARP CORNERS WITH 0.4 mm.
3. TOLERANCES WILL BE AS PER IS:3965-1981, UNLESS OTHERWISE SPECIFIED

PARTY'S NAME	KARNATAKA INDUSTRIES, BANGALORE
PARTY'S DRAWING No.	AS PER SAMPLE & REQUIREMENT
ALLOY & TEMPER	HE9 WP
DESCRIPTION	CLIP SECTION