

P-15375

S4760

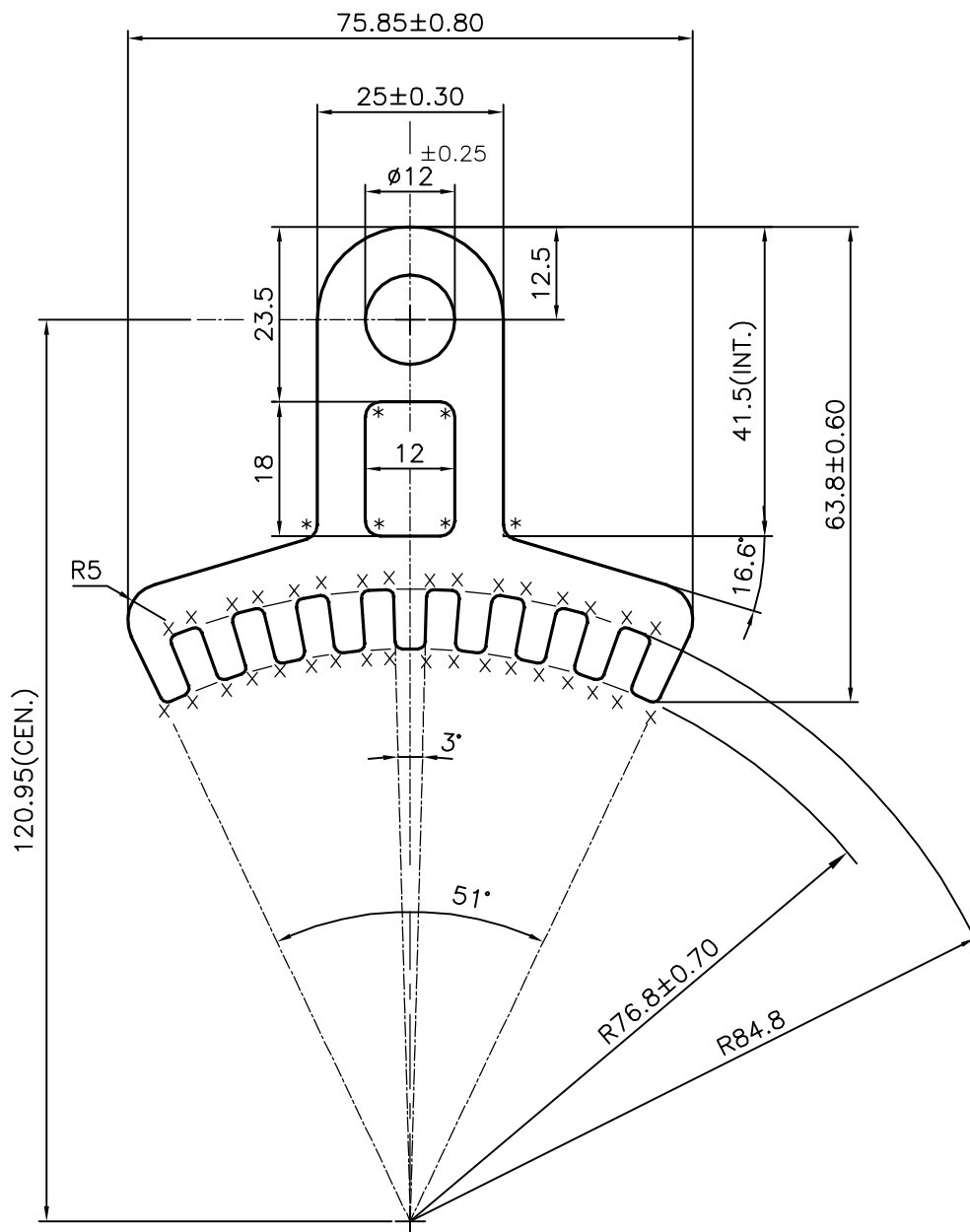

x = 1.0 RADIUS(34 PLACES)
 * = 2.0 RADIUS (6 PLACES)



SYMBOL OF QUALITY
 AN ISO 9001 COMPANY

JINDAL ALUMINIUM LTD.
 BANGALORE-560073 (INDIA)

	NAME	DATE
DRAWN	J.P.KAUSHIK	28-11-2015
CHECKED		
APPROVED	S.S.GARG	09-12-2015
SCALE		1:1
AREA mm ²		1510.297
PERIMETER mm.		364.764
WEIGHT kg/m		4.078
DRAWING No.	SECTION No.	
P-15375	-	
S4760	S4760	

1. ALL DIMENSIONS ARE IN mm.
2. ROUND OFF ALL SHARP CORNERS WITH 0.40 mm.
3. TOLERANCES WILL BE AS PER IS:6477-1983 UNLESS OTHERWISE SPECIFIED

PARTY'S NAME	IEEC POWER ELECTRONICS PVT. LTD., MUMBAI
PARTY'S DRAWING No.	A-6320-03
ALLOY & TEMPER	6063 T6
DESCRIPTION	147.6 ROLLER 9 FIN ELECTRODE PROFILE