

P-15349-2

S4762

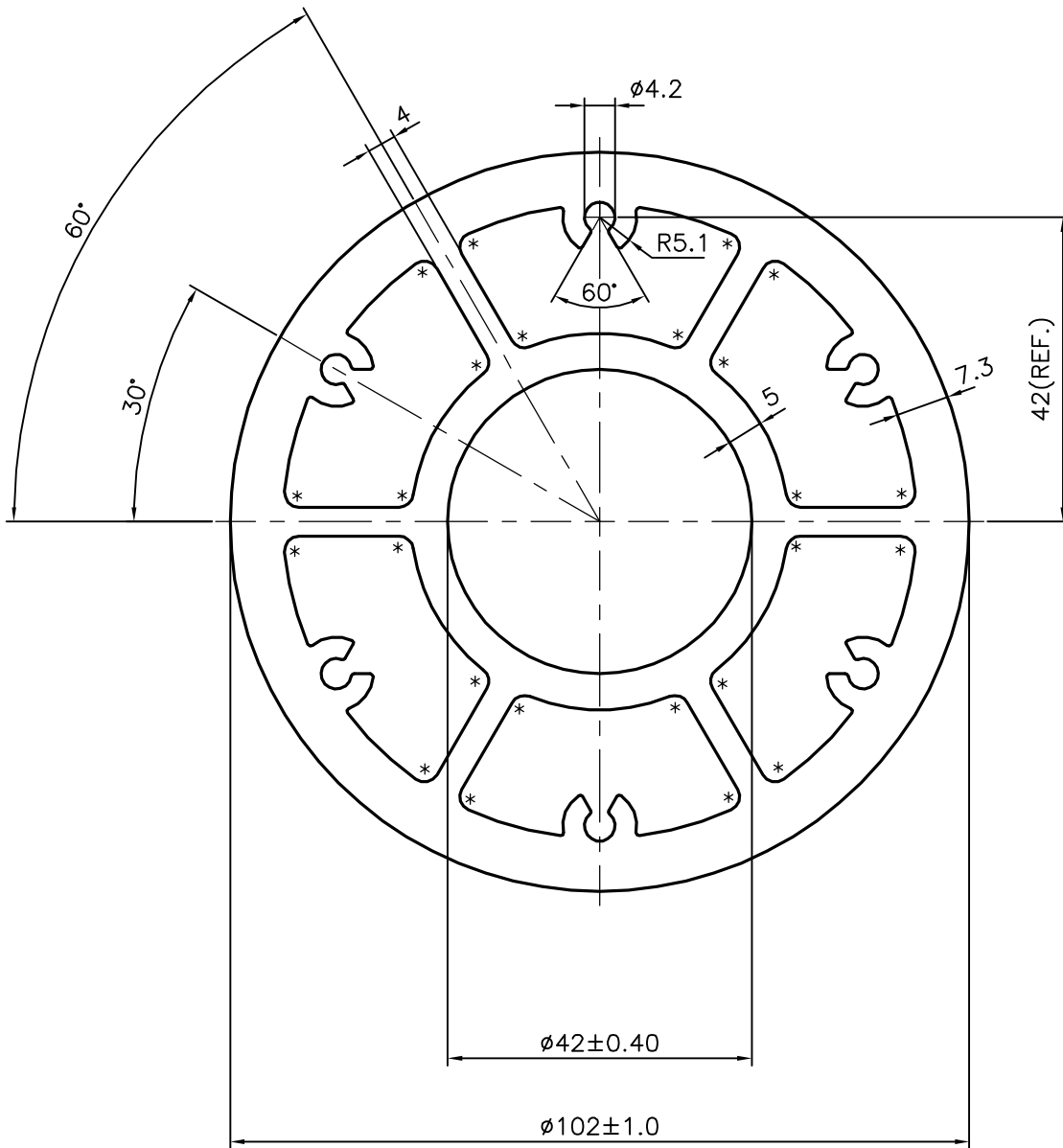

1. STRAIGHTNESS=1.7mm/M

2. TWIST=NOT APPLICABLE

* = 2.0 RADIUS (24 PLACES)



SYMBOL OF QUALITY
AN ISO 9001 COMPANY

JINDAL ALUMINIUM LTD.
BANGALORE-560073 (INDIA)

	NAME	DATE
DRAWN	J.P.KAUSHIK	03-12-2015
CHECKED		
APPROVED	S.S.GARG	09-12-2015
SCALE		1:1
AREA mm ²		3546.272
PERIMETER mm.		320.442
WEIGHT kg/m		9.575
DRAWING No.	SECTION No.	
P-15349-2	-	
S4762	S4762	

1. ALL DIMENSIONS ARE IN mm.
2. ROUND OFF ALL SHARP CORNERS WITH 0.40 mm.
3. TOLERANCES WILL BE AS PER IS:6477-1983 UNLESS OTHERWISE SPECIFIED

PARTY'S NAME	IEEC POWER ELECTRONICS PVT. LTD., MUMBAI
PARTY'S DRAWING No.	A-6320-01/01
ALLOY & TEMPER	6063 T6
DESCRIPTION	ALUMINIUM PROFILE ϕ 100mm