

P-15259-1

S4790

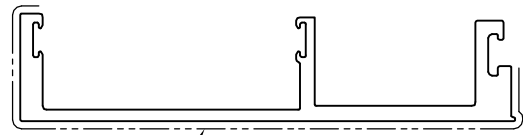
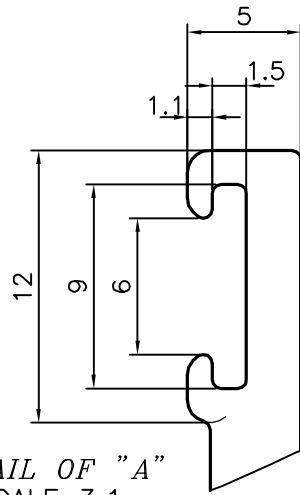

EXPOSED SURFACE

DETAIL OF "A"  
SCALE 3:1

TOLERANCE ON THICKNESS  $+0.30$   
 $-0.10$   
ANGULARITY =  $\pm 2^\circ$

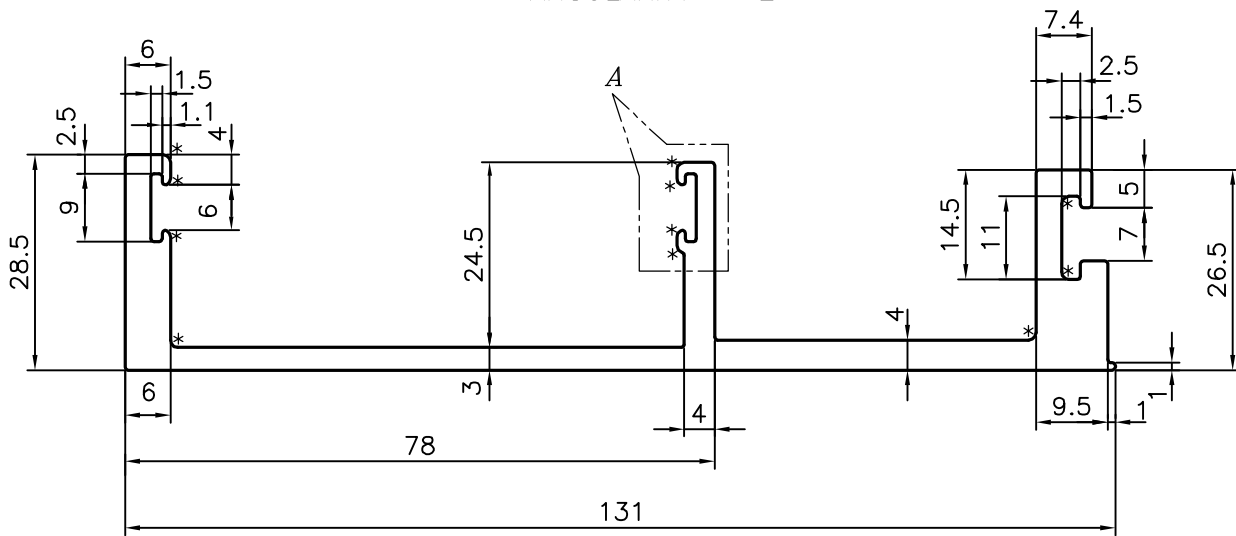

\* = 1.0 RADIUS (11 PLACES)



SYMBOL OF QUALITY  
AN ISO 9001 COMPANY

**JINDAL ALUMINIUM LTD.**  
BANGALORE-560073 (INDIA)

	NAME	DATE
DRAWN	J.P.KAUSHIK	09-11-2015
CHECKED		
APPROVED	S.S.GARG	22-12-2015
SCALE		1:1
AREA mm <sup>2</sup>		815.892
PERIMETER mm.		444.018
WEIGHT kg/m		2.203
DRAWING No.	SECTION No.	
P-15259-1	-	
S4790	S4790	

1. ALL DIMENSIONS ARE IN mm. 2. ROUND OFF ALL SHARP CORNERS WITH 0.40 mm. 3. TOLERANCES WILL BE AS PER IS:3965-1981, UNLESS OTHERWISE SPECIFIED	
PARTY'S NAME	OMKAR REALTORS & DEVELOPERS PVT. LTD., MUMBAI
PARTY'S DRAWING No.	AP-1619
ALLOY & TEMPER	6063 T6
DESCRIPTION	CURTAIN WALL SECTION