

P-15446

S4809

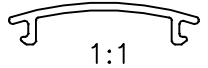

1:1

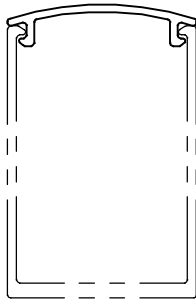
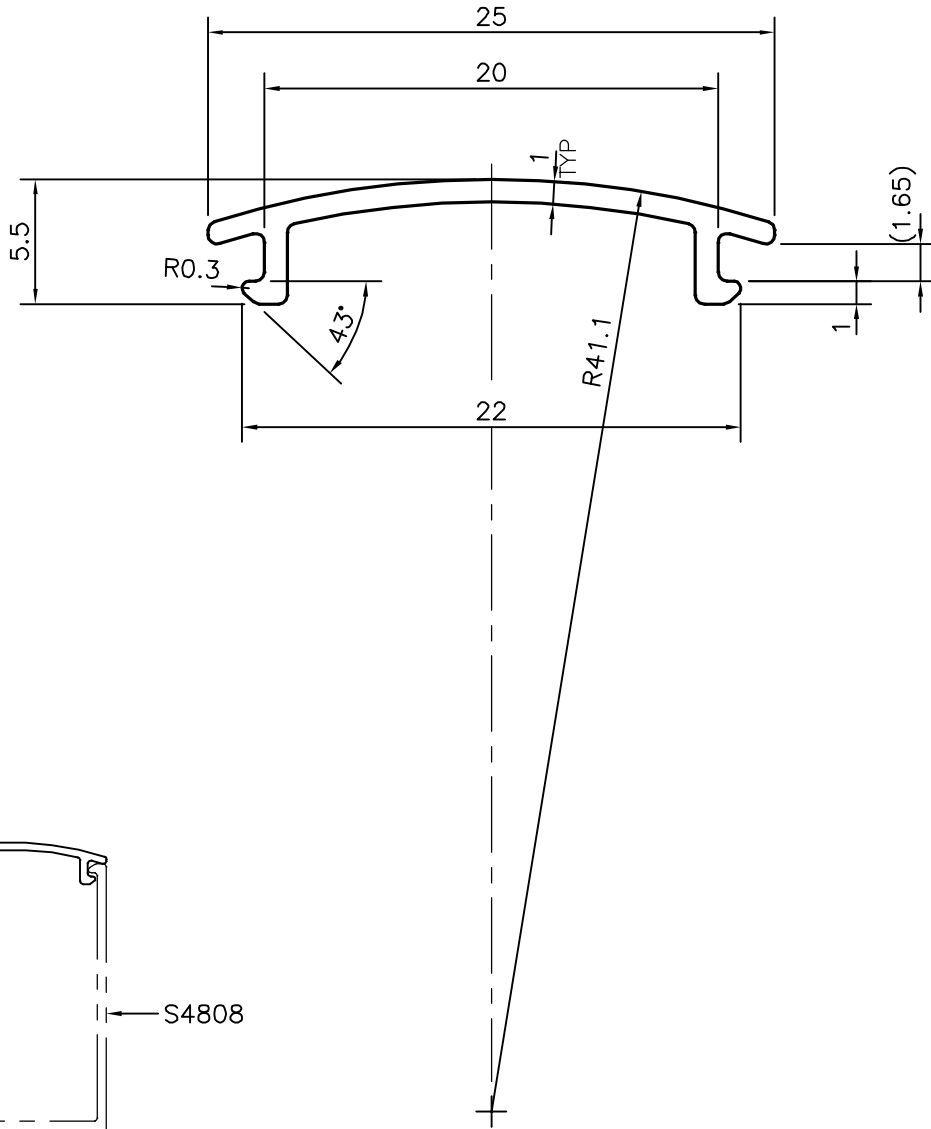

S4808



SYMBOL OF QUALITY  
AN ISO 9002 COMPANY

**JINDAL ALUMINIUM LTD.**  
BANGALORE-560073 (INDIA)

	NAME	DATE
DRAWN	J.P.KAUSHIK	19-12-2015
CHECKED		
APPROVED	S.S.GARG	28-12-2015
SCALE		3:1
AREA mm <sup>2</sup>		33.725
PERIMETER mm.		66.932
WEIGHT kg/m		0.091
DRAWING No.	SECTION No.	
P-15446	-	
S4809	S4809	

1. ALL DIMENSIONS ARE IN mm.
2. ROUND OFF ALL SHARP CORNERS WITH 0.40 mm.
3. TOLERANCES WILL BE AS PER IS:3965-1981 UNLESS OTHERWISE SPECIFIED

PARTY'S NAME	FULL SPACE INTERIORS, MUMBAI
PARTY'S DRAWING No.	FSI-AL-DIE-02
ALLOY & TEMPER	6063 T6
DESCRIPTION	COVER PLATE SECTION