

P-15447

S4810

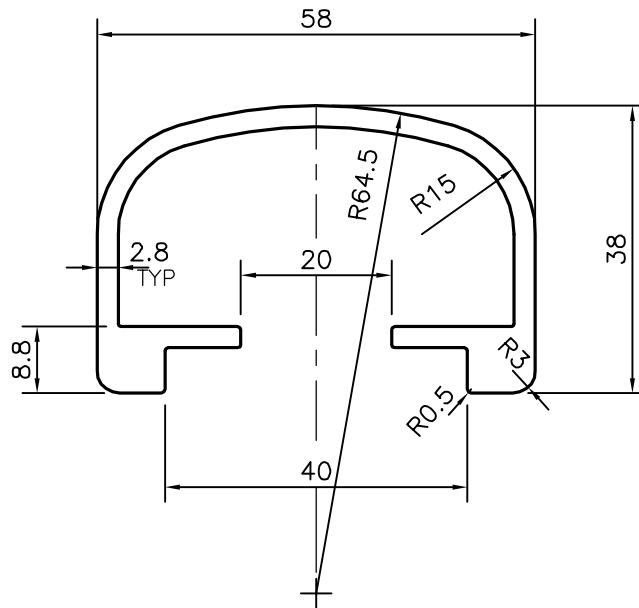

SYMBOL OF QUALITY
AN ISO 9002 COMPANY

JINDAL ALUMINIUM LTD.
BANGALORE-560073 (INDIA)

	NAME	DATE
DRAWN	J.P.KAUSHIK	19-12-2015
CHECKED		
APPROVED	S.S.GARG	28-12-2015

1. ALL DIMENSIONS ARE IN mm.
2. ROUND OFF ALL SHARP CORNERS WITH 0.40 mm.
3. TOLERANCES WILL BE AS PER IS:3965-1981 UNLESS OTHERWISE SPECIFIED

SCALE	1:1
AREA mm ²	477.749
PERIMETER mm.	292.164
WEIGHT kg/m	1.290

PARTY'S NAME	FULL SPACE INTERIORS, MUMBAI
PARTY'S DRAWING No.	FSI-AL-DIE-01
ALLOY & TEMPER	6063 T6
DESCRIPTION	HAND RAIL SECTION

DRAWING No.	SECTION No.
P-15447	-
S4810	S4810