

P-15386

S4812

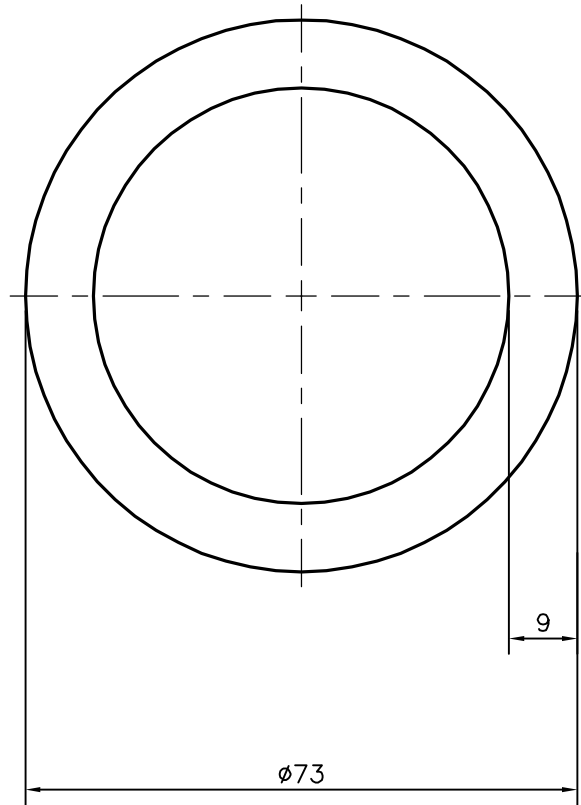

SYMBOL OF QUALITY
AN ISO 9002 COMPANY

JINDAL ALUMINIUM LTD.
BANGALORE-560073 (INDIA)

	NAME	DATE
DRAWN	J.P.KAUSHIK	01-12-2015
CHECKED		
APPROVED	S.S.GARG	31-12-2015
SCALE		1:1
AREA mm ²		1809.557
PERIMETER mm.		229.336
WEIGHT kg/m		4.886
DRAWING No.	SECTION No.	
P-15386	-	
S4812	S4812	

1. ALL DIMENSIONS ARE IN mm.
2. ROUND OFF ALL SHARP CORNERS WITH 0.40 mm.
3. TOLERANCES WILL BE AS PER IS:2673-2002 UNLESS OTHERWISE SPECIFIED

PARTY'S NAME	NATIONAL ALUMINIUM CO.LTD., ANGUL
PARTY'S DRAWING No.	AS PER SPECIFICATION
ALLOY & TEMPER	63401 WP
DESCRIPTION	ROUND TUBE