

P-15492

S4823

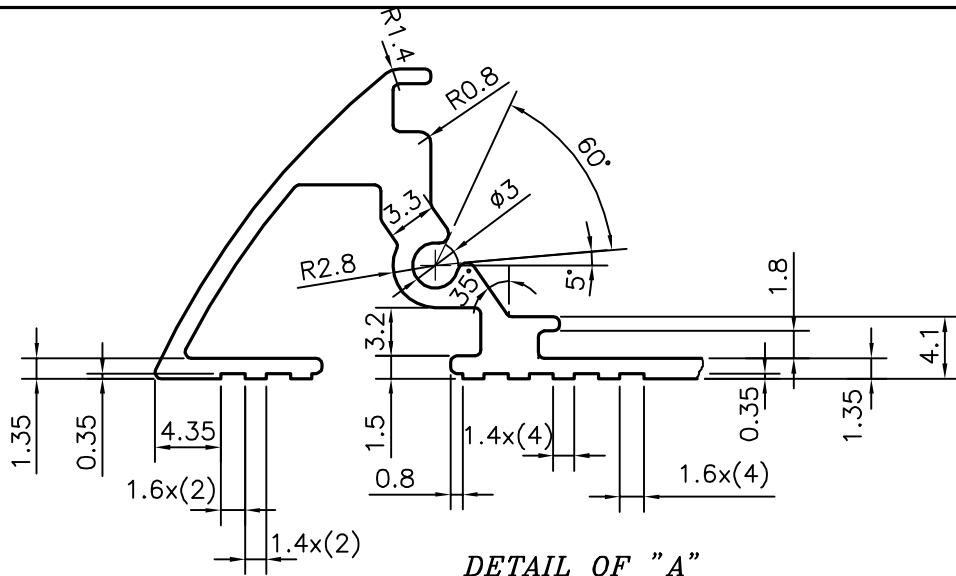

DETAIL OF "A"
SCALE 2:1

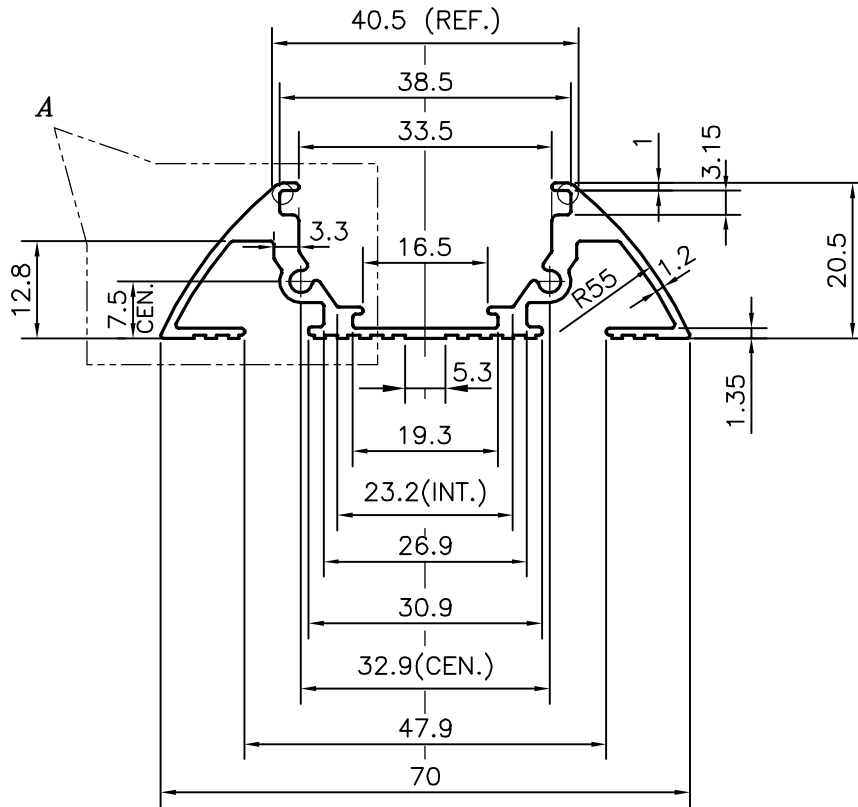

SYMBOL OF QUALITY
AN ISO 9001 COMPANY

JINDAL ALUMINIUM LTD.
BANGALORE-560073 (INDIA)

	NAME	DATE
DRAWN	J.P.KAUSHIK	08-01-2016
CHECKED		
APPROVED	S.S.GARG	13-01-2016
SCALE		1:1
AREA mm ²		267.709
PERIMETER mm.		304.871
WEIGHT kg/m		0.723
DRAWING No.	SECTION No.	
P-15492	-	
S4823	S4823	

1. ALL DIMENSIONS ARE IN mm.
2. ROUND OFF ALL SHARP CORNERS WITH 0.40 mm.
3. TOLERANCES WILL BE AS PER IS:3965-1981, UNLESS OTHERWISE SPECIFIED

PARTY'S NAME	ARKA TECHNOLOGIES PVT. LTD., BANGALORE
PARTY'S DRAWING No.	MODIFIED OF SECTION No:-25243
ALLOY & TEMPER	6063 T6
DESCRIPTION	LED LIGHT SECTION