

P-15517

S4831

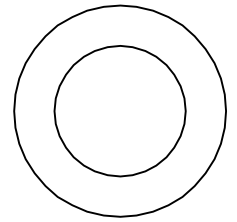

1:1

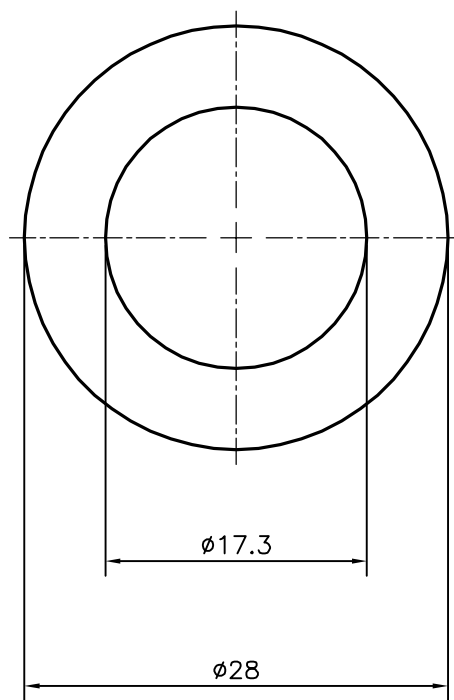

SYMBOL OF QUALITY
AN ISO 9001 COMPANY

JINDAL ALUMINIUM LTD.
BANGALORE-560073 (INDIA)

	NAME	DATE
DRAWN	J.P.KAUSHIK	22-01-2016
CHECKED		
APPROVED	S.S.GARG	27-01-2016
SCALE		2:1
AREA mm ²		380.69
PERIMETER mm.		87.965
WEIGHT kg/m		1.028
DRAWING No.	SECTION No.	
P-15517	-	
S4831	S4831	

1. ALL DIMENSIONS ARE IN mm.
2. ROUND OFF ALL SHARP CORNERS WITH 0.40 mm.
3. TOLERANCES WILL BE AS PER, IS:2673-2002 UNLESS OTHERWISE SPECIFIED

PARTY'S NAME	S.S.INDUSTRIES, BANGALORE
PARTY'S DRAWING No.	AS PER SPECIFICATION
ALLOY & TEMPER	6061 'O'
DESCRIPTION	ROUND TUBE