

P-15563

S4840

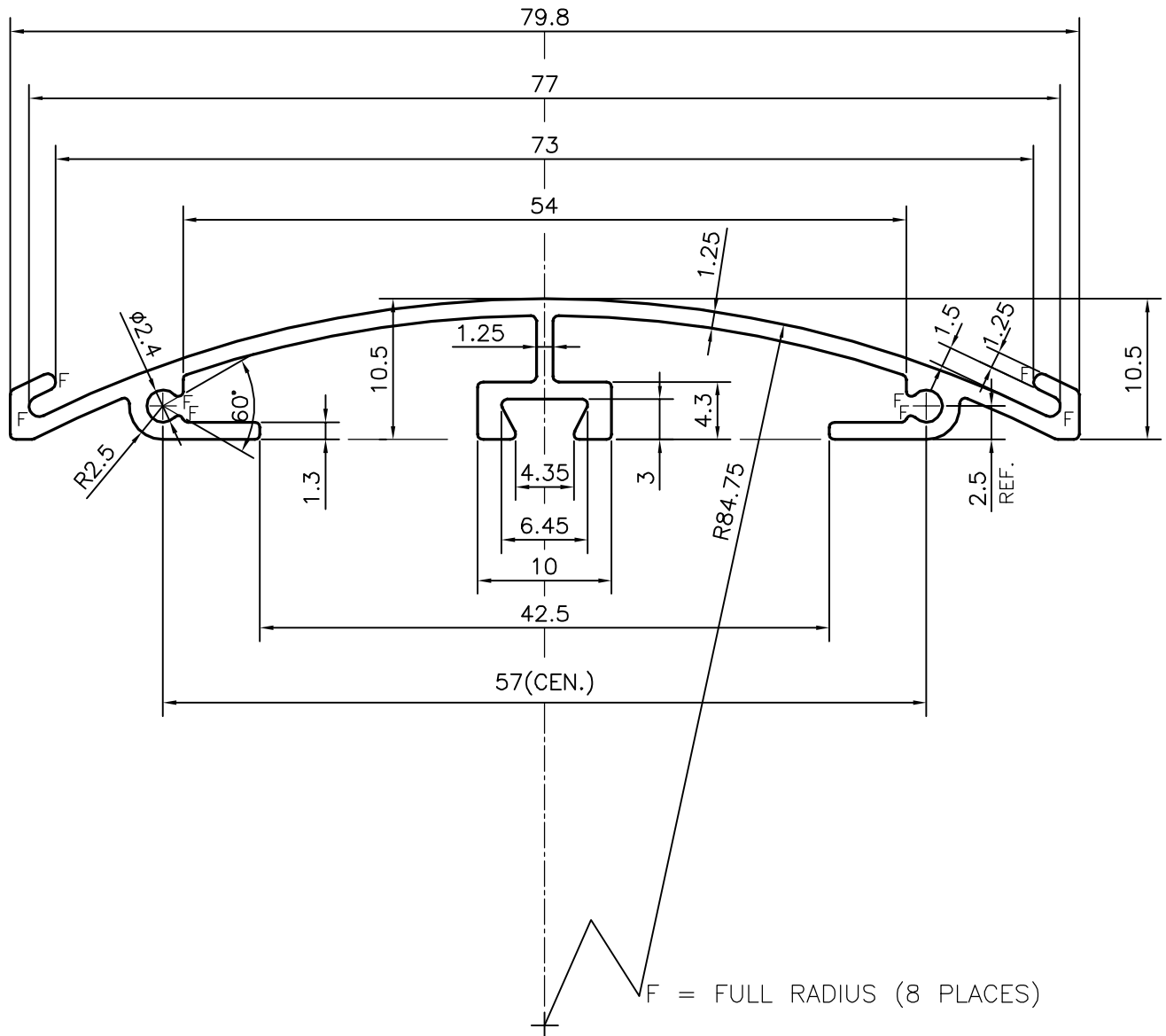

F = FULL RADIUS (8 PLACES)

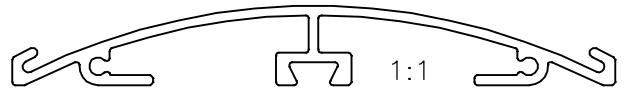

SYMBOL OF QUALITY
AN ISO 9001 COMPANY

JINDAL ALUMINIUM LTD.
BANGALORE-560073 (INDIA)

	NAME	DATE
DRAWN	J.P.KAUSHIK	02-02-2016
CHECKED		
APPROVED	B. NATARAJ	05-02-2016
SCALE		2:1
AREA mm ²		184.205
PERIMETER mm.		271.675
WEIGHT kg/m		0.497
DRAWING No.	SECTION No.	
P-15563	-	
S4840	S4840	

1. ALL DIMENSIONS ARE IN mm.
2. ROUND OFF ALL SHARP CORNERS WITH 0.40 mm.
3. TOLERANCES WILL BE AS PER, IS:3965-1981 UNLESS OTHERWISE SPECIFIED

PARTY'S NAME	SAMEER ENTERPRISES, NEW DELHI
PARTY'S DRAWING No.	AS PER SAMPLE
ALLOY & TEMPER	6063 T6
DESCRIPTION	DISPLAY SECTION