

P-15591-1

S4845

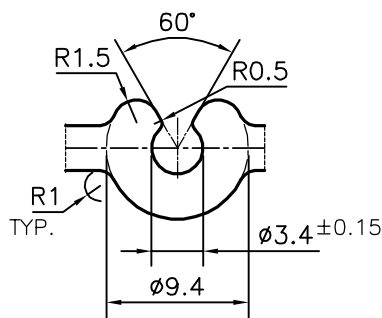
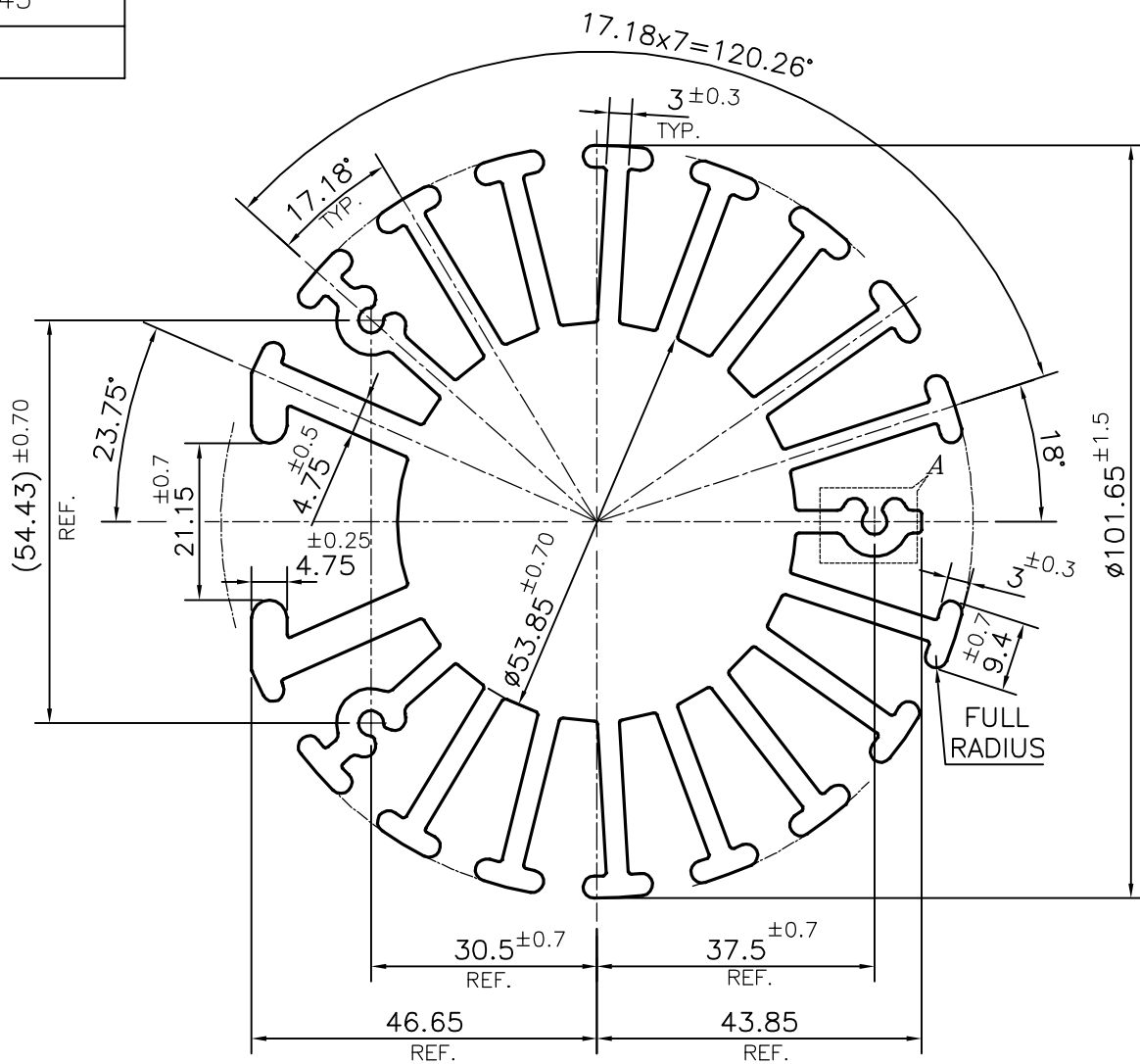

DETAIL OF "A"  
SCALE 2:1

ANGULARITY :- ±2.0°



SYMBOL OF QUALITY  
AN ISO 9001 COMPANY

**JINDAL ALUMINIUM LTD.**  
BANGALORE-560073 (INDIA)

	NAME	DATE
DRAWN	PARVESH	10-02-2016
CHECKED		
APPROVED	B. NATARAJ	16-02-2016
SCALE		1:1
AREA mm <sup>2</sup>		4109.965
PERIMETER mm.		1278.035
WEIGHT kg/m		11.097
DRAWING No.	SECTION No.	
P-15591-1	-	
S4845	S4845	

1. ALL DIMENSIONS ARE IN mm.
2. ROUND OFF ALL SHARP CORNERS WITH 0.40 mm.
3. TOLERANCES WILL BE AS PER IS:3965-1981, UNLESS OTHERWISE SPECIFIED

PARTY'S NAME	AUTO DIECASTING COMPANY, COIMBATORE
PARTY'S DRAWING No.	AS PER AUTOCAD DRAWING-93034096
ALLOY & TEMPER	6063 T6
DESCRIPTION	ROUND HEAT SINK SECTION