

P-15609

S4854

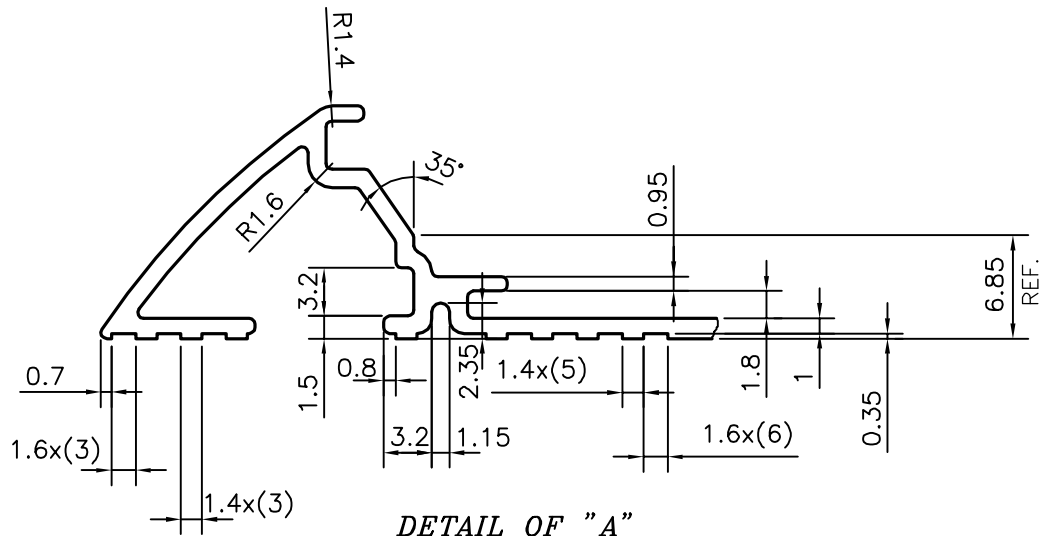

DETAIL OF "A"
SCALE 2:1

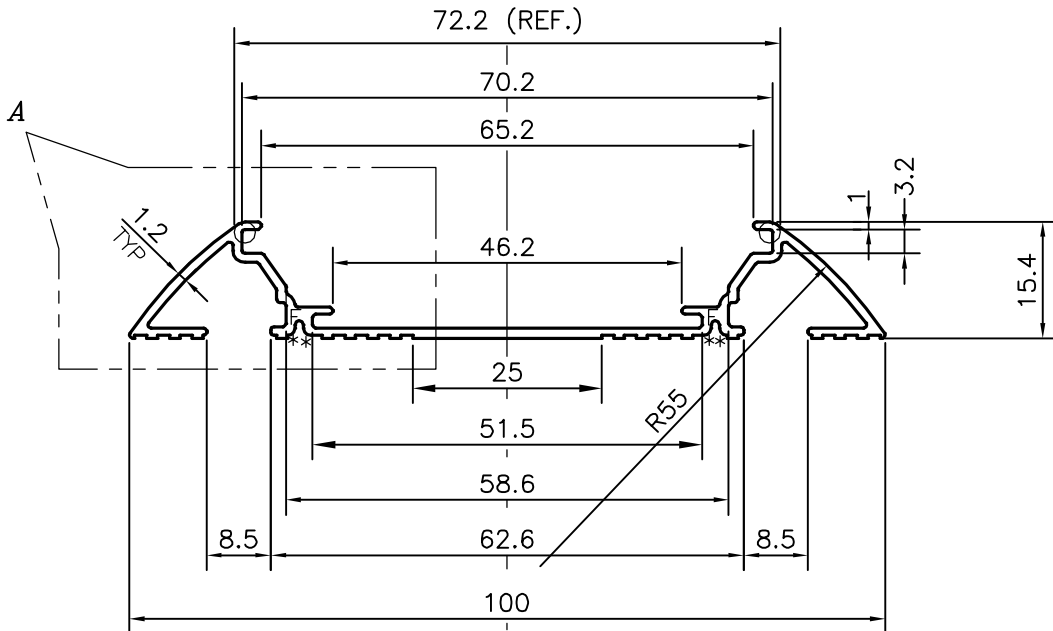

F = FULL RADIUS (2 PLACES)
* = 1.0 RADIUS (4 PLACES)



SYMBOL OF QUALITY
AN ISO 9001 COMPANY

JINDAL ALUMINIUM LTD.
BANGALORE-560073 (INDIA)

	NAME	DATE
DRAWN	J.P.KAUSHIK	19-02-2016
CHECKED		
APPROVED	S.S.GARG	23-02-2016
SCALE		1:1
AREA mm ²		203.644
PERIMETER mm.		339.085
WEIGHT kg/m		0.550
DRAWING No.	SECTION No.	
P-15609	-	
S4854	S4854	

1. ALL DIMENSIONS ARE IN mm.
2. ROUND OFF ALL SHARP CORNERS WITH 0.40 mm.
3. TOLERANCES WILL BE AS PER IS:3965-1981, UNLESS OTHERWISE SPECIFIED

PARTY'S NAME	ARKA TECHNOLOGIES PVT. LTD., BANGALORE
PARTY'S DRAWING No.	MODIFIED OF SECTION No:-25243
ALLOY & TEMPER	6063 T6
DESCRIPTION	LED LIGHT SECTION