

P-15610

S4855

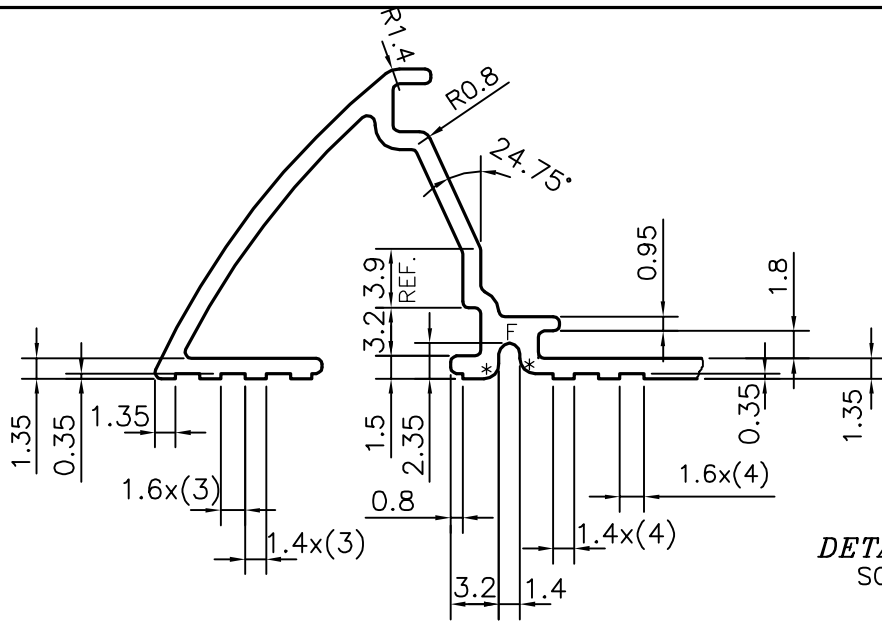

DETAIL OF "A"
SCALE 2:1

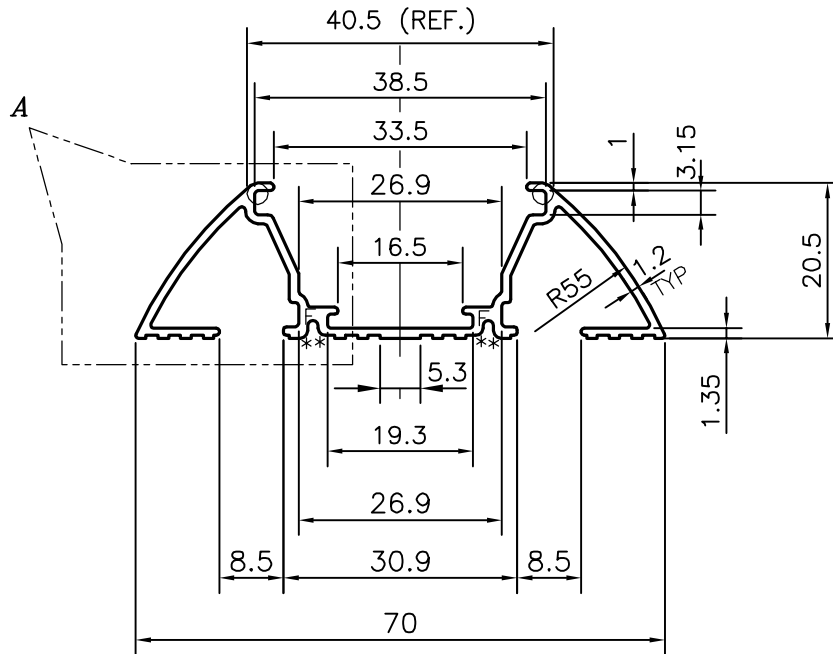

F = FULL RADIUS (2 PLACES)
* = 1.0 RADIUS (4 PLACES)

 SYMBOL OF QUALITY AN ISO 9001 COMPANY	JINDAL ALUMINIUM LTD. BANGALORE-560073 (INDIA)	NAME	DATE
		DRAWN	J.P.KAUSHIK 19-02-2016
		CHECKED	
		APPROVED	S.S.GARG 23-02-2016
		SCALE	1:1
		AREA mm ²	185.54
		PERIMETER mm.	306.307
		WEIGHT kg/m	0.501
PARTY'S NAME	ARKA TECHNOLOGIES PVT. LTD., BANGALORE	DRAWING No.	SECTION No.
PARTY'S DRAWING No.	MODIFIED OF SECTION No:-S4823	P-15610	-
ALLOY & TEMPER	6063 T6	S4855	S4855
DESCRIPTION	LED LIGHT SECTION		