

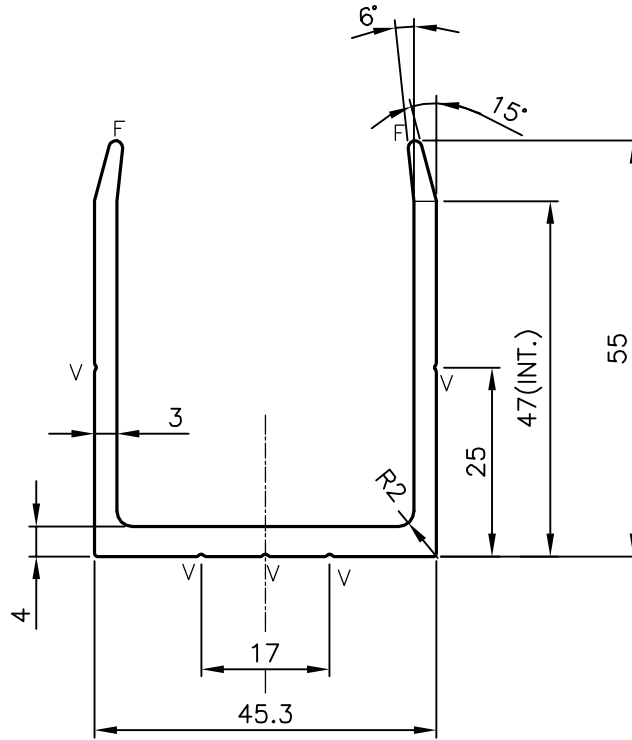

P-15616

S4860



F = FULL RADIUS (2 PLACES)

V = V GROOVE 0.3x90° ( 5 PLACES)

 SYMBOL OF QUALITY AN ISO 9001 COMPANY	<b>JINDAL ALUMINIUM LTD.</b> BANGALORE-560073 (INDIA)	NAME		DATE
		DRAWN	J.P.KAUSHIK	19-02-2016
1. ALL DIMENSIONS ARE IN mm. 2. ROUND OFF ALL SHARP CORNERS WITH 0.40 mm. 3. TOLERANCES WILL BE AS PER IS:3965-1981 UNLESS OTHERWISE SPECIFIED		CHECKED		
		APPROVED	S.S.GARG	24-03-2016
PARTY'S NAME D-GLAZE, GHAZIABAD		SCALE		1:1
		AREA mm <sup>2</sup>		476.958
PARTY'S DRAWING No. AS PER AutoCAD DRAWING		PERIMETER mm.		298.133
		WEIGHT kg/m		1.288
ALLOY & TEMPER 6063 T6		DRAWING No.	SECTION No.	
		P-15616	-	
DESCRIPTION MISC. SECTION		S4860	S4860	