

P-15557-1

S4869

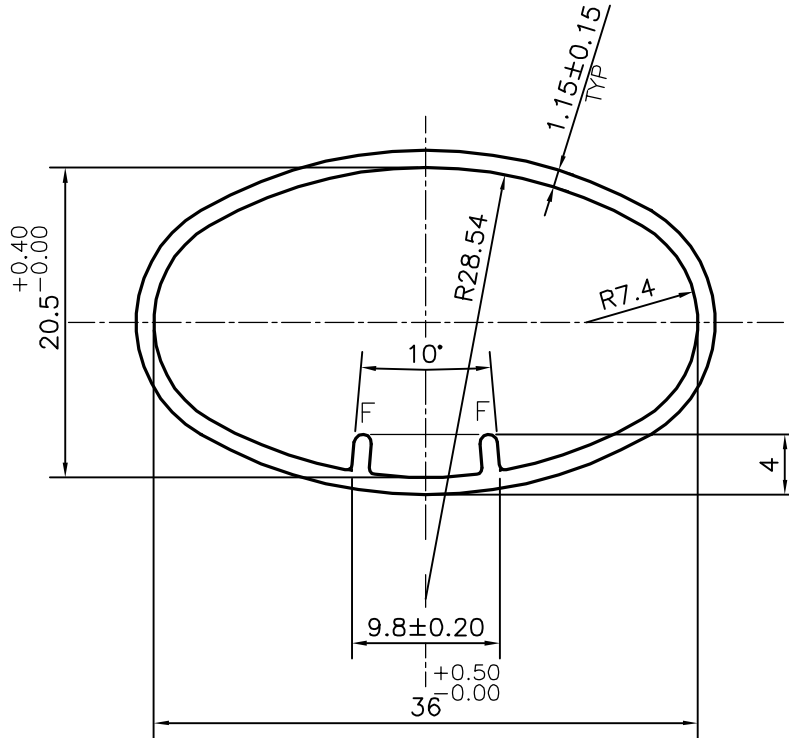

F = FULL RADIUS (2 PLACES)

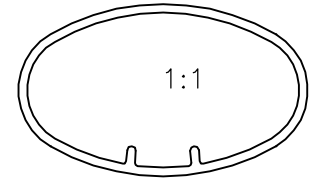

SYMBOL OF QUALITY
AN ISO 9001 COMPANY

JINDAL ALUMINIUM LTD.
BANGALORE-560073 (INDIA)

	NAME	DATE
DRAWN	J.P.KAUSHIK	26-02-2016
CHECKED		
APPROVED	S.S.GARG	01-03-2016
SCALE		2:1
AREA mm ²		114.374
PERIMETER mm.		98.136
WEIGHT kg/m		0.309
DRAWING No.	SECTION No.	
P-15557-1	-	
S4869	S4869	

1. ALL DIMENSIONS ARE IN mm.
2. ROUND OFF ALL SHARP CORNERS WITH 0.40 mm.
3. TOLERANCES WILL BE AS PER, IS:6477-1983 UNLESS OTHERWISE SPECIFIED

PARTY'S NAME	STOVEKRAFT PVT. LTD., BANGALORE
PARTY'S DRAWING No.	ND EXT 000 01 & REQUIREMENT
ALLOY & TEMPER	6063 T6
DESCRIPTION	FLAME GUARD SECTION