

P-15213-1

S4896

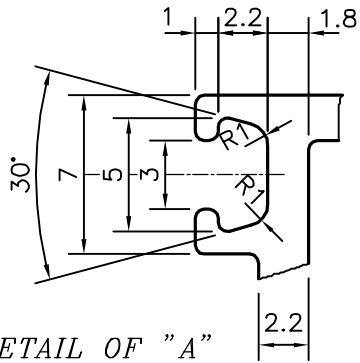

DETAIL OF "A"  
SCALE 3:1

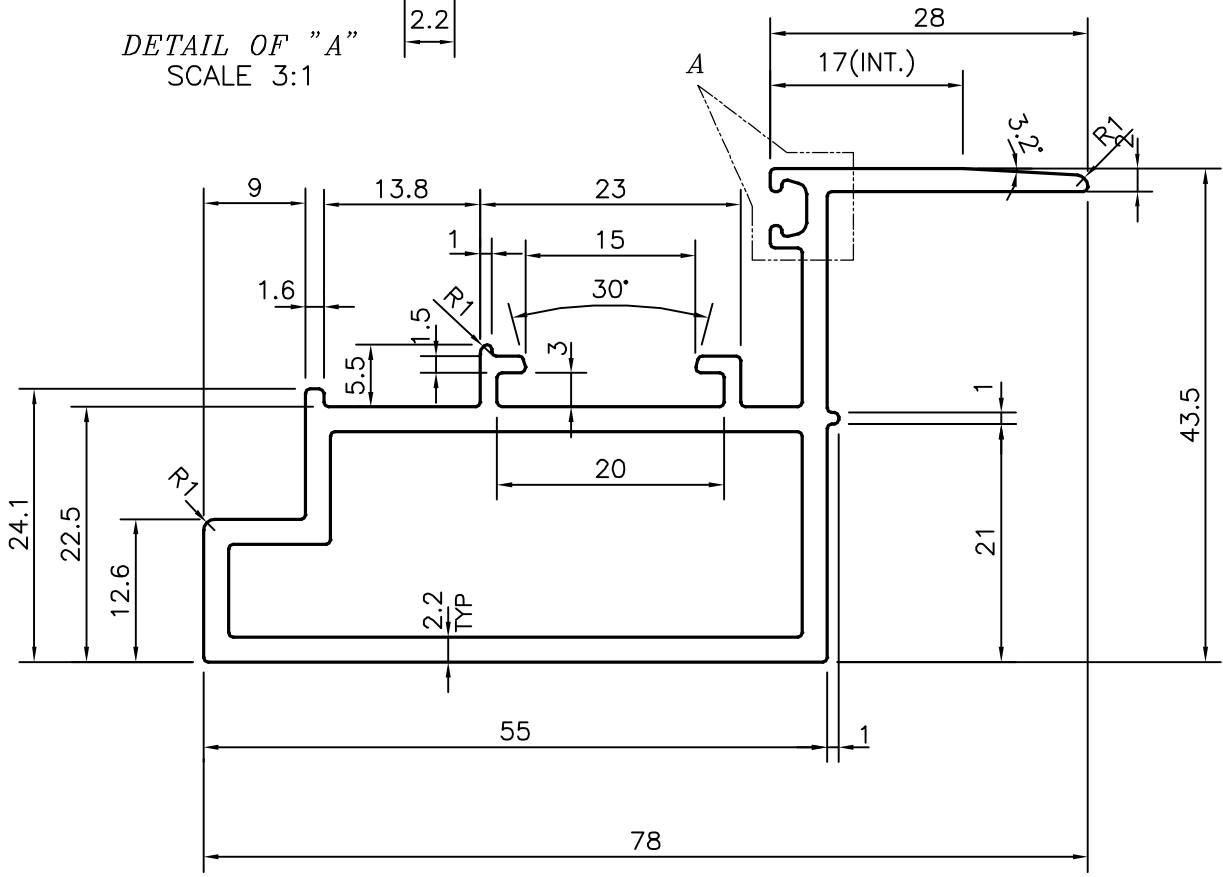
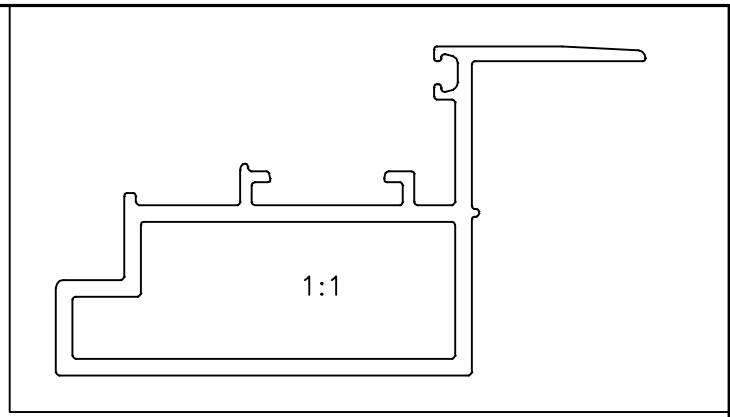

SYMBOL OF QUALITY  
AN ISO 9002 COMPANY

**JINDAL ALUMINIUM LTD.**  
BANGALORE-560073 (INDIA)

	NAME	DATE
DRAWN	J.P.KAUSHIK	05-04-2016
CHECKED		
APPROVED	S.S. GARG	06-04-2016

1. ALL DIMENSIONS ARE IN mm.
2. ROUND OFF ALL SHARP CORNERS WITH 0.40 mm.
3. TOLERANCES WILL BE AS PER IS:6477-1983 UNLESS OTHERWISE SPECIFIED

SCALE	1.5:1
AREA mm <sup>2</sup>	441.913
PERIMETER mm.	284.882
WEIGHT kg/m	1.193

PARTY'S NAME	AHLUWALIA CONTRACTS INDIA LTD., NEW DELHI
PARTY'S DRAWING No.	AS PER AutoCAD DRAWING
ALLOY & TEMPER	HE9 WP
DESCRIPTION	CURTAIN WALL SECTION

DRAWING No.	SECTION No.
P-15213-1	-
S4896	S4896