

P-15214-1

S4897

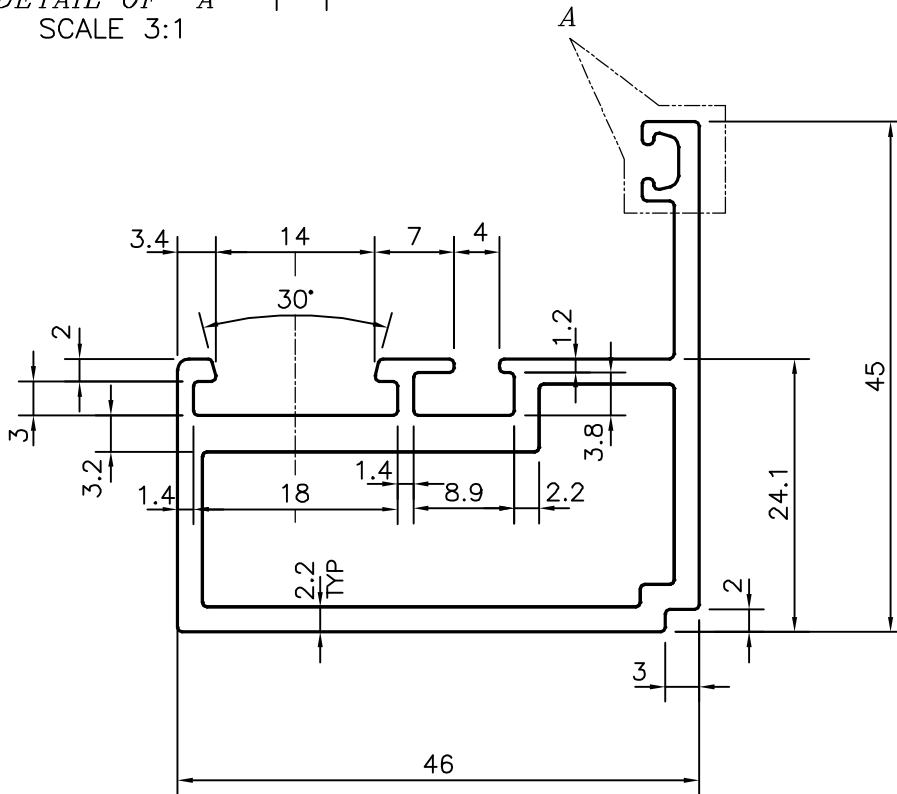
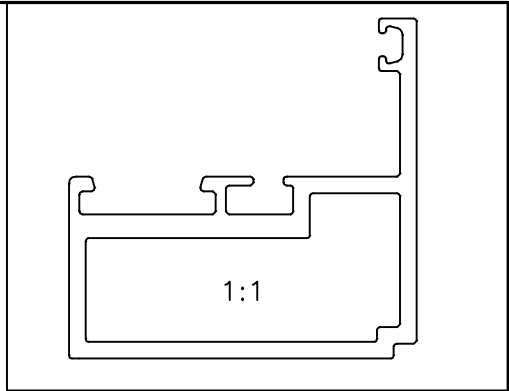
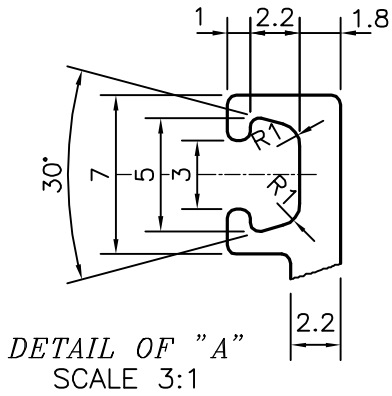

SYMBOL OF QUALITY
AN ISO 9002 COMPANY

JINDAL ALUMINIUM LTD.
BANGALORE-560073 (INDIA)

	NAME	DATE
DRAWN	J.P.KAUSHIK	04-03-2016
CHECKED		
APPROVED	S.S. GARG	04-04-2016
SCALE		1.5:1
AREA mm ²		398.426
PERIMETER mm.		228.225
WEIGHT kg/m		1.076
DRAWING No.	SECTION No.	
P-15214-1	-	
S4897	S4897	

1. ALL DIMENSIONS ARE IN mm.
2. ROUND OFF ALL SHARP CORNERS WITH 0.40 mm.
3. TOLERANCES WILL BE AS PER IS:6477-1983 UNLESS OTHERWISE SPECIFIED

PARTY'S NAME	AHLUWALIA CONTRACTS INDIA LTD., NEW DELHI
PARTY'S DRAWING No.	AS PER AutoCAD DRAWING
ALLOY & TEMPER	HE9 WP
DESCRIPTION	CURTAIN WALL SECTION