

P-15762

S4908

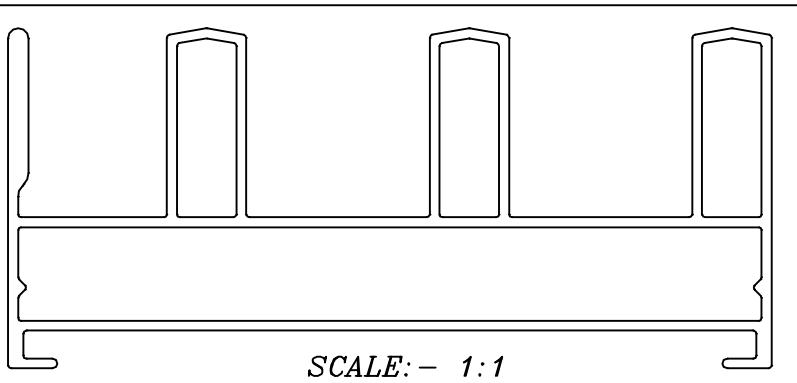

F = FULL RADIUS (3 PLACES)

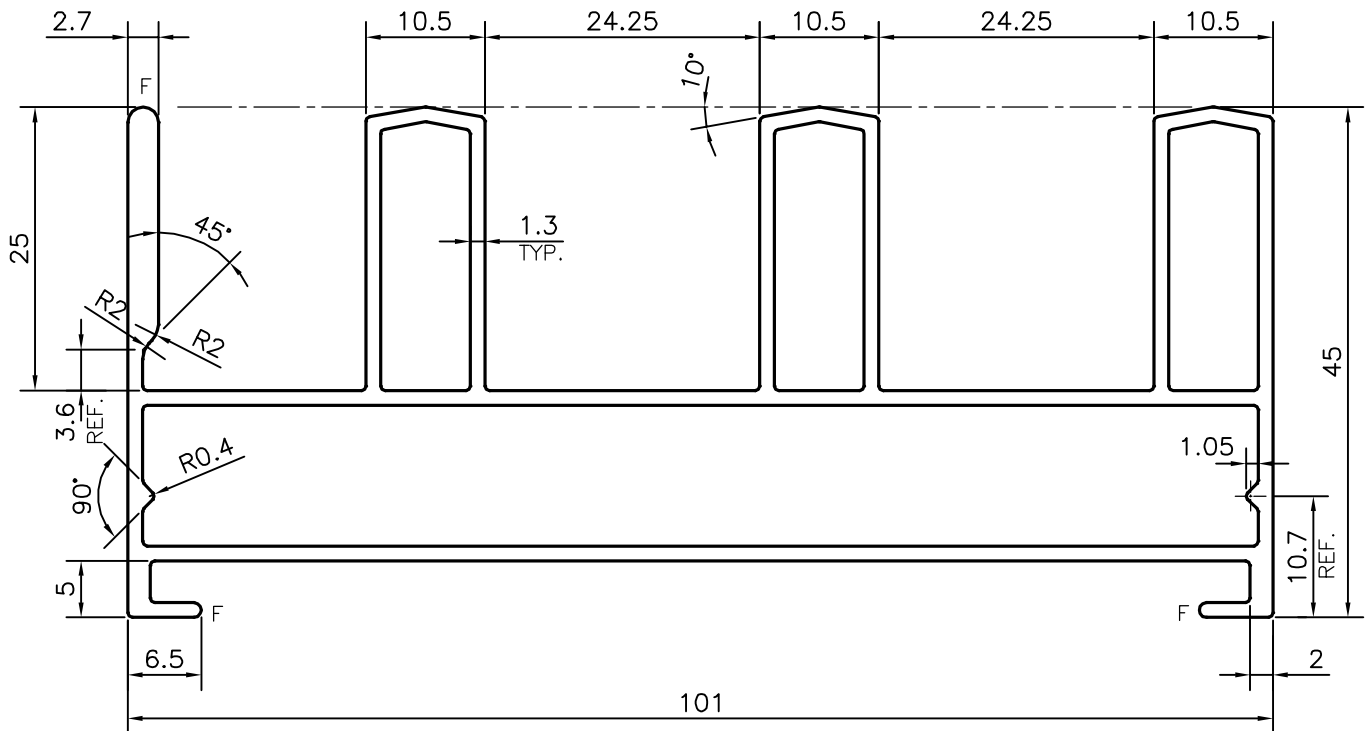

SYMBOL OF QUALITY
AN ISO 9001 COMPANY

JINDAL ALUMINIUM LTD.
BANGALORE-560073 (INDIA)

	NAME	DATE
DRAWN	PARVESH	07-04-2016
CHECKED		
APPROVED	S.S. GARG	12-04-2016
SCALE		1.5:1
AREA mm ²		610.401
PERIMETER mm.		461.761
WEIGHT kg/m		1.648
DRAWING No.	SECTION No.	
P-15762	-	
S4908	S4908	

1. ALL DIMENSIONS ARE IN mm.
2. ROUND OFF ALL SHARP CORNERS WITH 0.40 mm.
3. TOLERANCES WILL BE AS PER IS:6477-1983 , UNLESS OTHERWISE SPECIFIED

PARTY'S NAME	NEST, BANGALORE
PARTY'S DRAWING No.	AS PER REQUIREMENT
ALLOY & TEMPER	6063 T6
DESCRIPTION	WINDOW SECTION