

P-15763-1

S4909

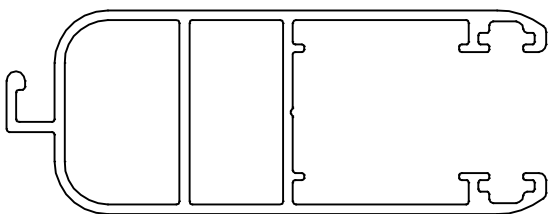
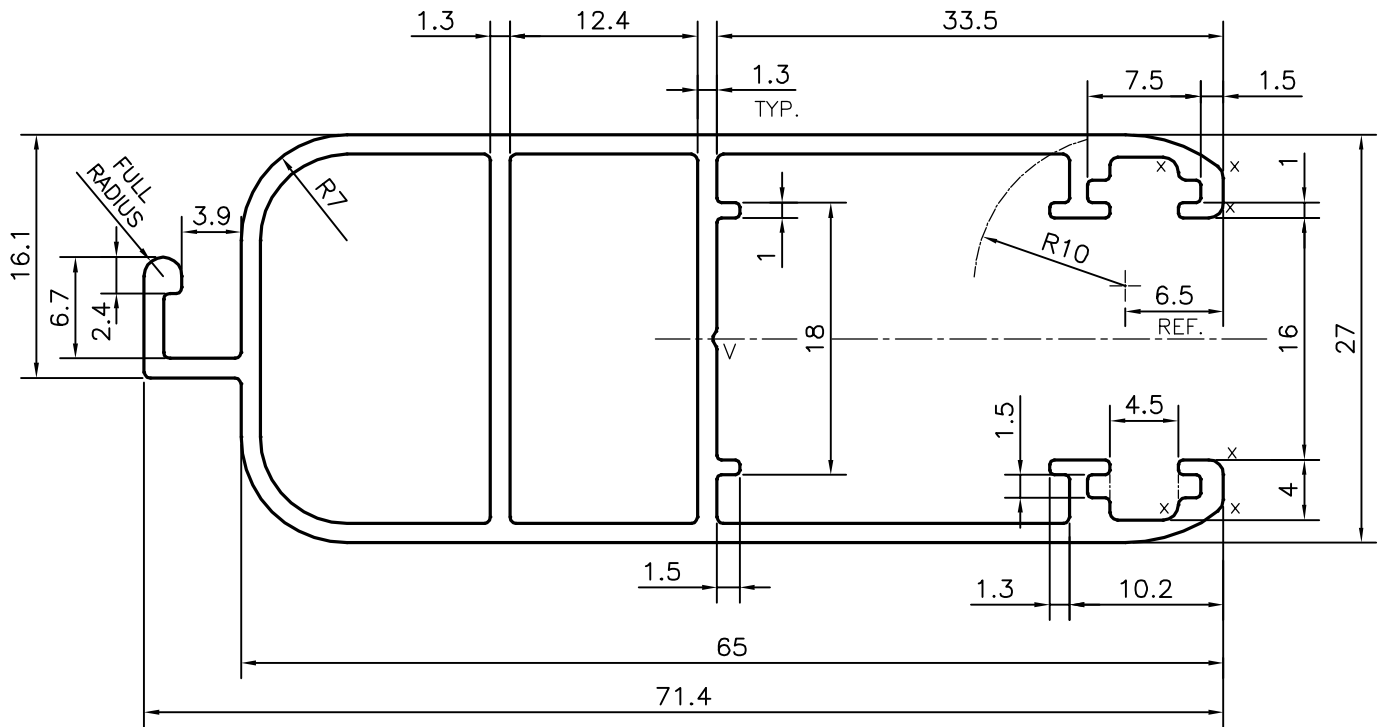

SCALE: - 1:1

X = RADIUS 1 mm. (6 PLACE)
 V = VEE GROOVE 0.3x120° (1 PLACE)



SYMBOL OF QUALITY
 AN ISO 9001 COMPANY

JINDAL ALUMINIUM LTD.
 BANGALORE-560073 (INDIA)

	NAME	DATE
DRAWN	PARVESH	09-04-2016
CHECKED		
APPROVED	S.S. GARG	12-04-2016
SCALE		2:1
AREA mm ²		312.812
PERIMETER mm.		316.473
WEIGHT kg/m		0.845
DRAWING No.	SECTION No.	
P-15763-1	-	
S4909	S4909	

1. ALL DIMENSIONS ARE IN mm.
2. ROUND OFF ALL SHARP CORNERS WITH 0.40 mm.
3. TOLERANCES WILL BE AS PER IS:6477-1983 , UNLESS OTHERWISE SPECIFIED

PARTY'S NAME	NEST, BANGALORE
PARTY'S DRAWING No.	AS PER REQUIREMENT
ALLOY & TEMPER	6063 T6
DESCRIPTION	WINDOW SECTION