

P-15702

S4915

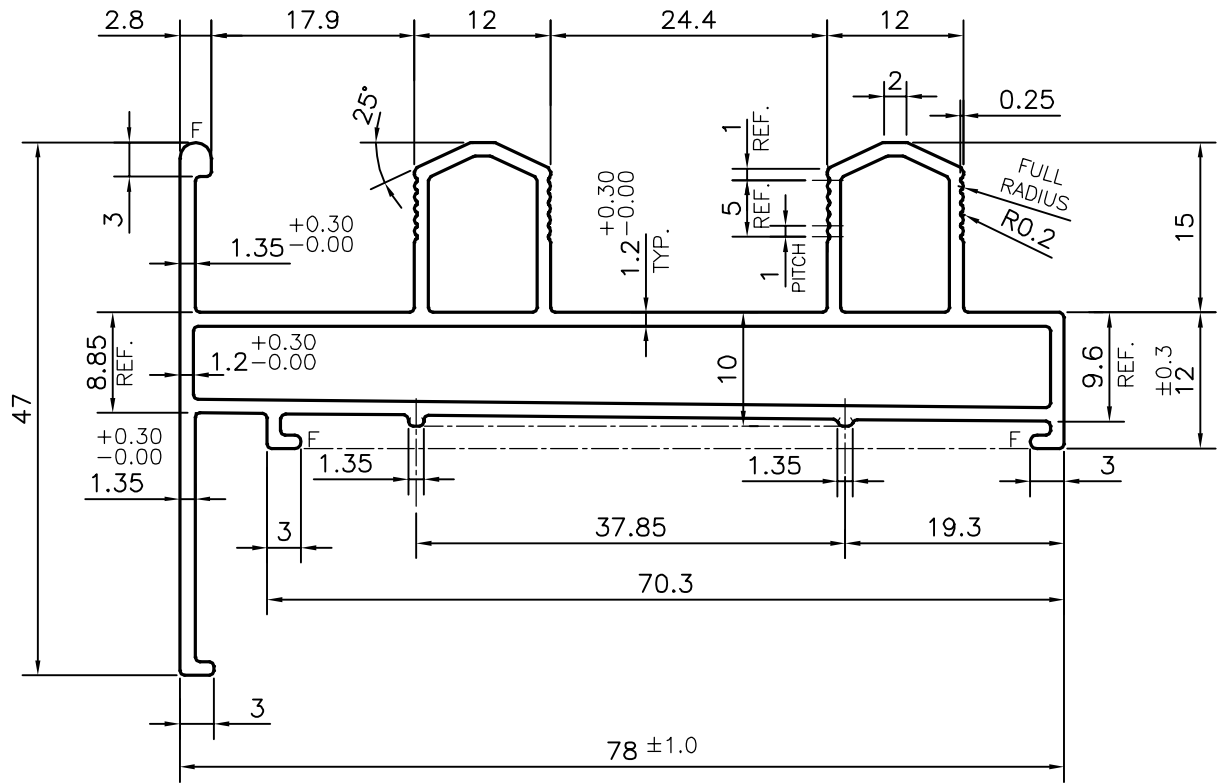

F = FULL RADIUS 3 PLACES)

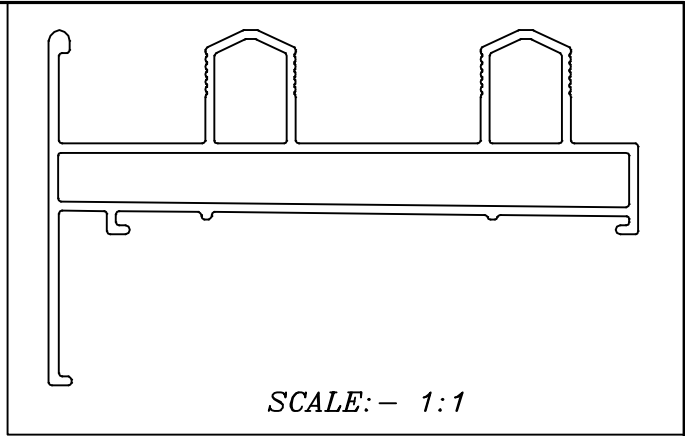

SYMBOL OF QUALITY  
AN ISO 9001 COMPANY

**JINDAL ALUMINIUM LTD.**  
BANGALORE-560073 (INDIA)

	NAME	DATE
DRAWN	PARVESH	21-03-2016
CHECKED		
APPROVED	S.S. GARG	20-04-2016
SCALE		1.5:1
AREA mm <sup>2</sup>		358.223
PERIMETER mm.		327.436
WEIGHT kg/m		0.967
DRAWING No.	SECTION No.	
P-15702	-	
S4915	S4915	

1. ALL DIMENSIONS ARE IN mm.
2. ROUND OFF ALL SHARP CORNERS WITH 0.40 mm.
3. TOLERANCES WILL BE AS PER IS:6477-1983 , UNLESS OTHERWISE SPECIFIED

PARTY'S NAME	PARAMOUNT INDUSTRIES, BANGALORE
PARTY'S DRAWING No.	P-AL172414L3
ALLOY & TEMPER	HE9 WP
DESCRIPTION	WINDOW SECTION