

P-15108

S4916

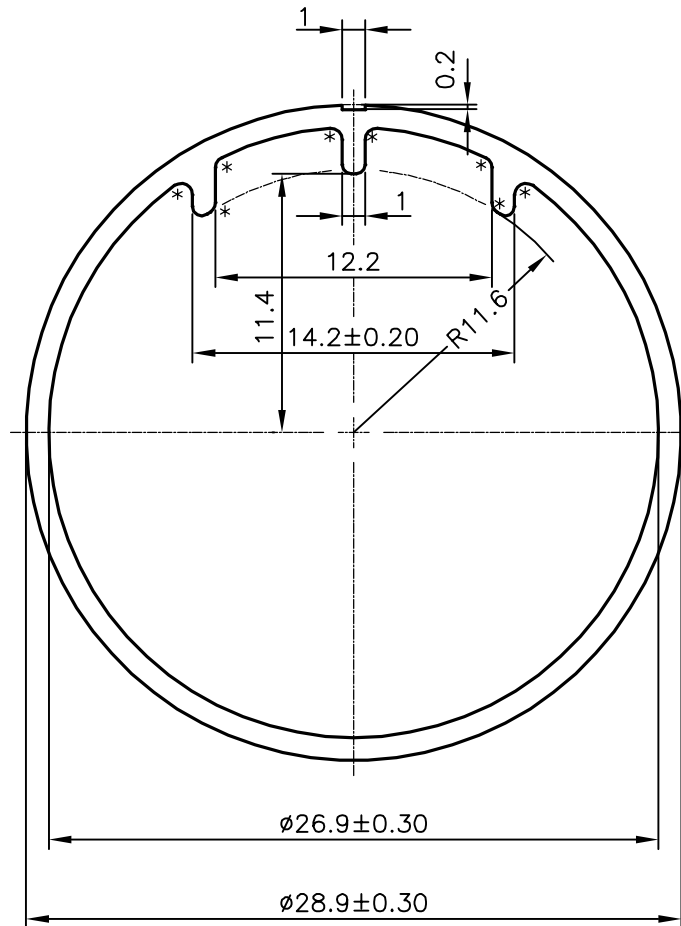

* = 0.5 RADIUS (8 PLACES)

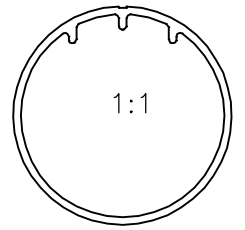

SYMBOL OF QUALITY
AN ISO 9001 COMPANY

JINDAL ALUMINIUM LTD.
BANGALORE-560073 (INDIA)

	NAME	DATE
DRAWN	J.P.KAUSHIK	31-08-2015
CHECKED		
APPROVED	S.S. GARG	23-04-2016
SCALE		3:1
AREA mm ²		94.067
PERIMETER mm.		91.192
WEIGHT kg/m		0.254
DRAWING No.	SECTION No.	
P-15108	-	
S4916	S4916	

1. ALL DIMENSIONS ARE IN mm.
2. ROUND OFF ALL SHARP CORNERS WITH 0.40 mm.
3. TOLERANCES WILL BE AS PER IS:6477-1983 UNLESS OTHERWISE SPECIFIED

PARTY'S NAME	NBT EXPORTS PVT. LTD., MUMBAI
PARTY'S DRAWING No.	AS PER DRAWING
ALLOY & TEMPER	6063 T5
DESCRIPTION	VENETIAN BLIND SECTION