

P-15109-1

S4917

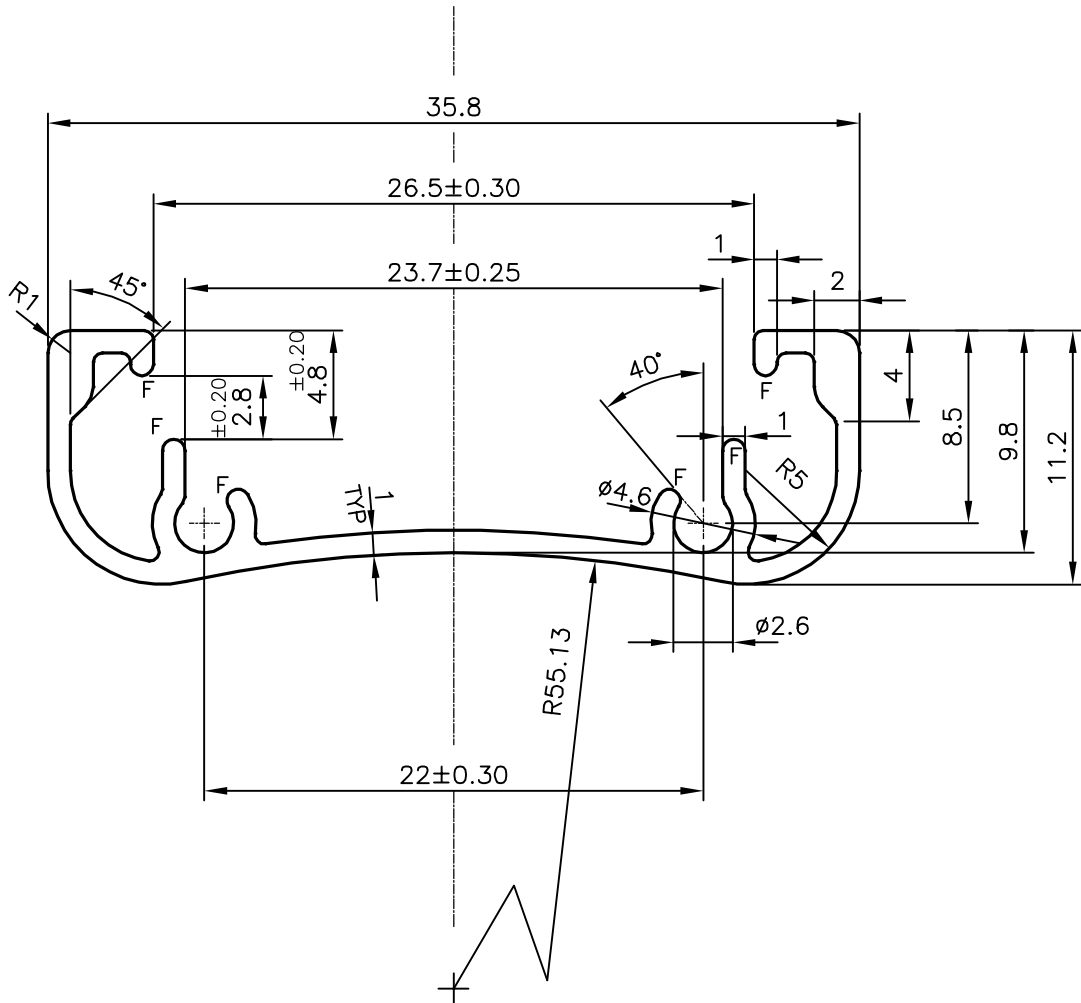

F = FULL RADIUS (6 PLACES)

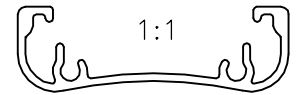

SYMBOL OF QUALITY  
AN ISO 9001 COMPANY

**JINDAL ALUMINIUM LTD.**  
BANGALORE-560073 (INDIA)

	NAME	DATE
DRAWN	J.P.KAUSHIK	27-09-2015
CHECKED		
APPROVED	S.S. GARG	23-04-2016
SCALE		3:1
AREA mm <sup>2</sup>		83.506
PERIMETER mm.		149.524
WEIGHT kg/m		0.225
DRAWING No.	SECTION No.	
P-15109-1	-	
S4917	S4917	

1. ALL DIMENSIONS ARE IN mm.
2. ROUND OFF ALL SHARP CORNERS WITH 0.40 mm.
3. TOLERANCES WILL BE AS PER IS:3965-1981 UNLESS OTHERWISE SPECIFIED

PARTY'S NAME	NBT EXPORTS PVT. LTD., MUMBAI
PARTY'S DRAWING No.	AS PER DRAWING
ALLOY & TEMPER	6063 T5
DESCRIPTION	VENETIAN BLIND SECTION