

P-15834

S4937

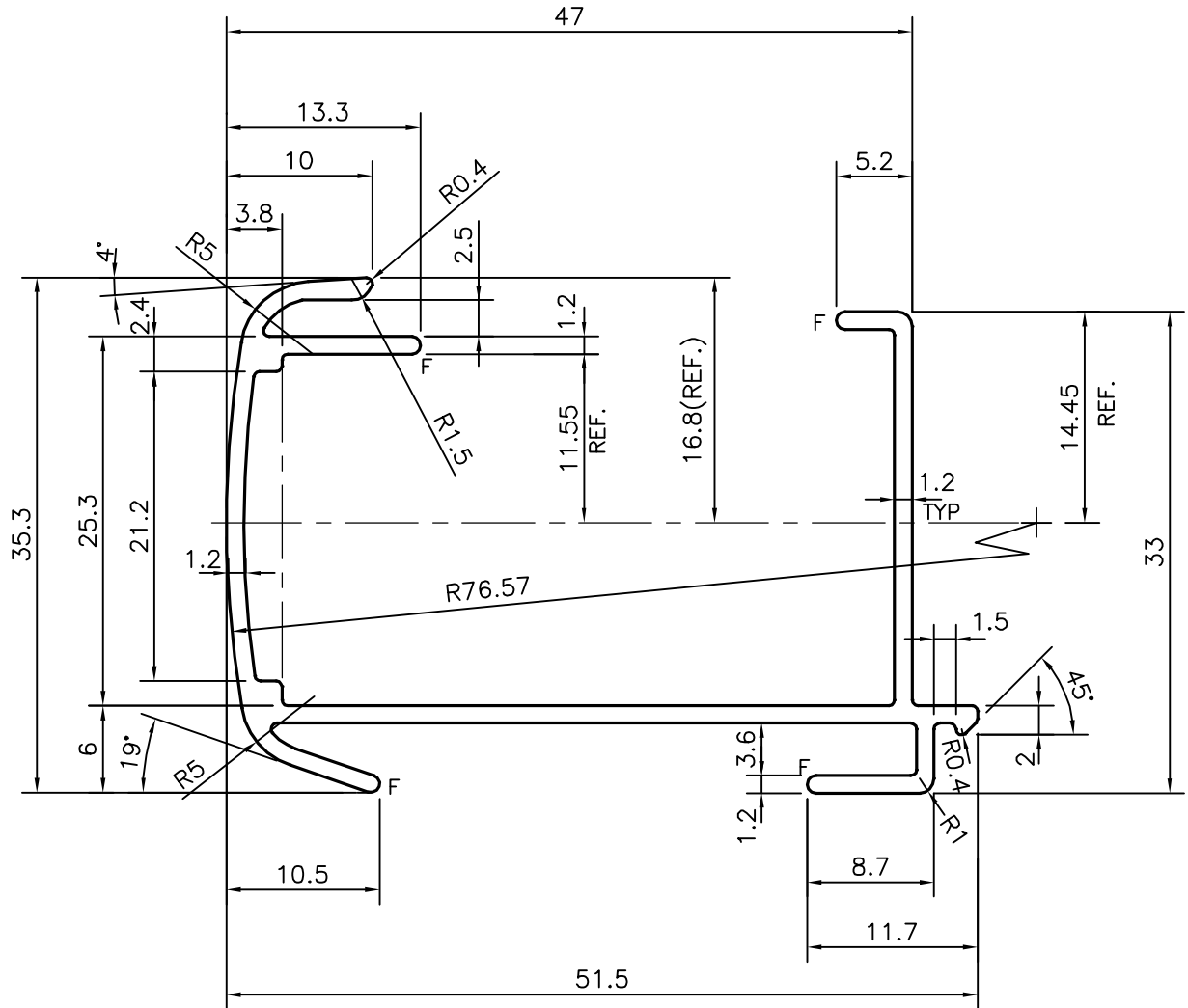

F = FULL RADIUS (4 PLACES)

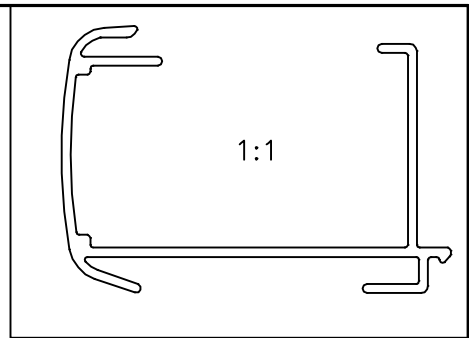

SYMBOL OF QUALITY
AN ISO 9002 COMPANY

JINDAL ALUMINIUM LTD.
BANGALORE-560073 (INDIA)

	NAME	DATE
DRAWN	J.P.KAUSHIK	06-05-2016
CHECKED		
APPROVED	B. NATARAJ	11-05-2016
SCALE		2:1
AREA	mm ²	185.373
PERIMETER	mm.	296.091
WEIGHT	kg/m	0.501
DRAWING No.	SECTION No.	
P-15834	-	
S4937	S4937	

1. ALL DIMENSIONS ARE IN mm.
2. ROUND OFF ALL SHARP CORNERS WITH 0.40 mm.
3. TOLERANCES WILL BE AS PER IS:3965-1981 UNLESS OTHERWISE SPECIFIED

PARTY'S NAME	MAC LIFESTYLE PRODUCTS LTD., NEW DELHI
PARTY'S DRAWING No.	AS PER DRAWING
ALLOY & TEMPER	6063 T6
DESCRIPTION	MISC. SECTION