

P-15823-1

S4941

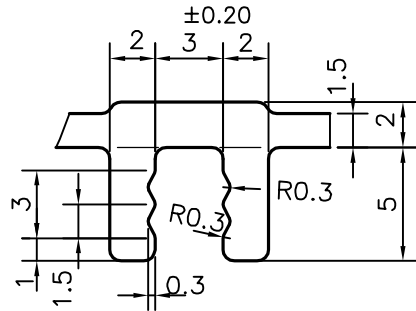

DETAIL OF "A"
SCALE 3:1

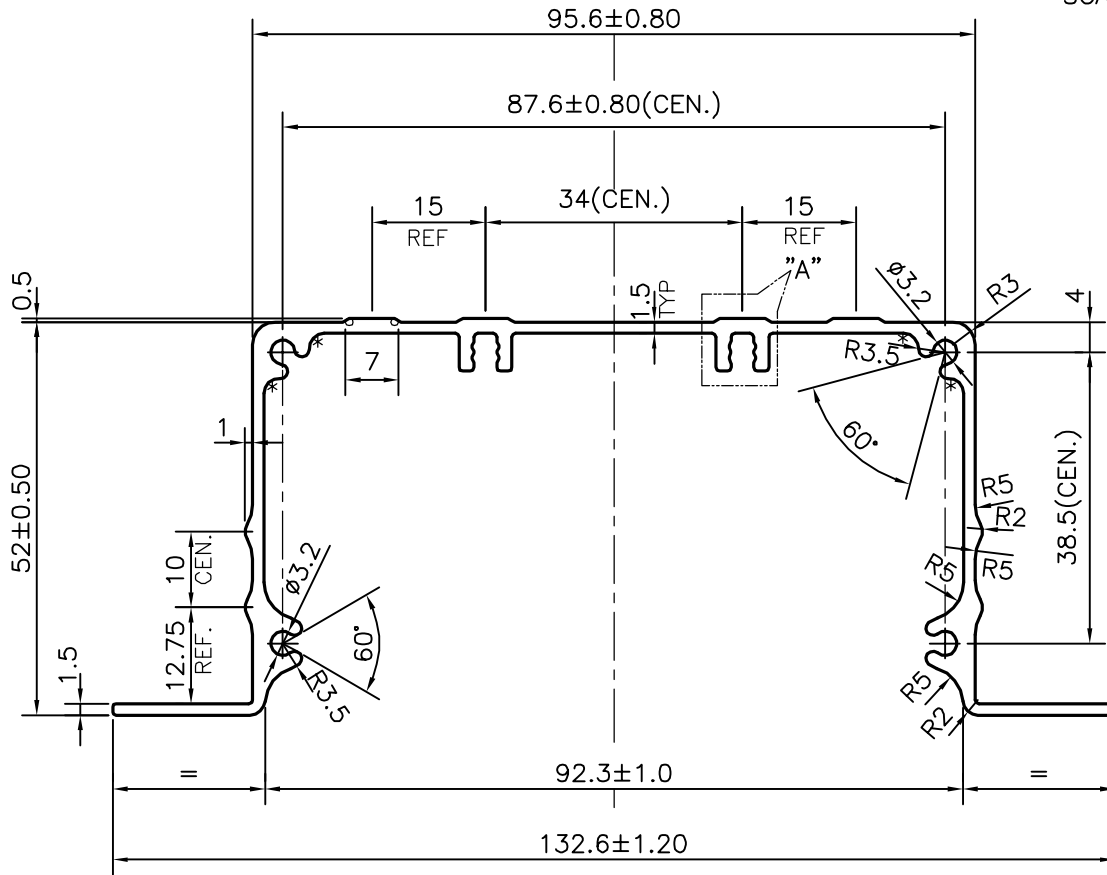

UNSPECIFIED RADIUS 0.5 mm

* = 2.0 RADIUS (4 PLACES)



SYMBOL OF QUALITY
AN ISO 9001 COMPANY

JINDAL ALUMINIUM LTD.
BANGALORE-560073 (INDIA)

	NAME	DATE
DRAWN	J.P.KAUSHIK	11-05-2016
CHECKED		
APPROVED	S.S. GARG	16-05-2016
SCALE		1:1
AREA mm ²		513.768
PERIMETER mm.		537.002
WEIGHT kg/m		1.387
DRAWING No.	SECTION No.	
P-15823-1	-	
S4941	S4941	

1. ALL DIMENSIONS ARE IN mm.
2. ROUND OFF ALL SHARP CORNERS WITH 0.40 mm.
3. TOLERANCES WILL BE AS PER IS:3965-1981 UNLESS OTHERWISE SPECIFIED

PARTY'S NAME	GOLDWYN LTD., NOIDA
ISSUE No.	GW15511 REV.01
ALLOY & TEMPER	6063 T6
DESCRIPTION	UPPER EXTRUSION SECTION