

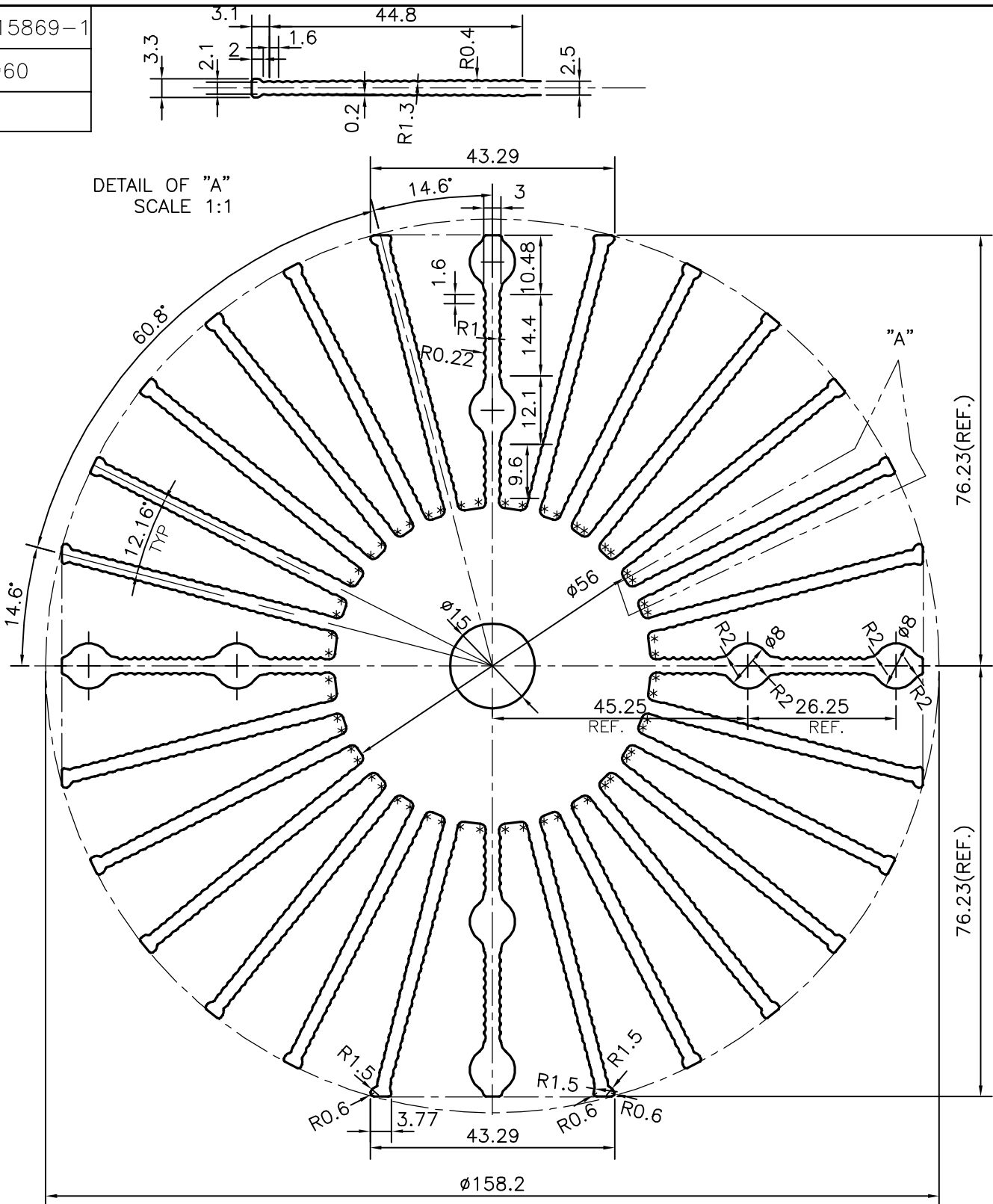

P-15869-1
S4960



* = 1.0 RADIUS (55 PLACES)

 SYMBOL OF QUALITY AN ISO 9001 COMPANY	JINDAL ALUMINIUM LTD. BANGALORE-560073 (INDIA)	NAME	DATE
		DRAWN	J.P.KAUSHIK 12-07-2016
		CHECKED	
		APPROVED	S.S. GARG 13-07-2016
		SCALE	1:1
		AREA mm ²	6087.613
		PERIMETER mm.	3151.001
		WEIGHT kg/m	16.437
PARTY'S NAME	PROMPTEC RENEWABLE ENERGY SOLUTIONS PVT. LTD., BANGALORE	DRAWING No.	SECTION No.
PARTY'S DRAWING No.	AS PER AutoCAD DRAWING & REQUIREMENT	P-15869-1	-
ALLOY & TEMPER	HE9 WP	S4960	S4960(ISSUE-2)
DESCRIPTION	ROUND HEAT SINK SECTION		