

P-16070

S5001

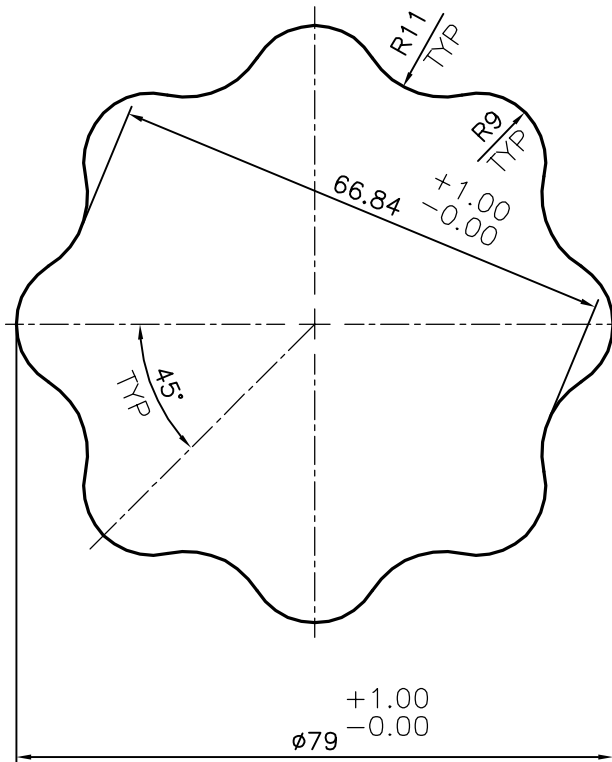

SYMBOL OF QUALITY
AN ISO 9001 COMPANY

JINDAL ALUMINIUM LTD.
BANGALORE-560073 (INDIA)

	NAME	DATE
DRAWN	J.P.KAUSHIK	02-07-2016
CHECKED		
APPROVED	S.S. GARG	06-07-2016
SCALE		1:1
AREA	mm ²	4202.7
PERIMETER	mm.	255.955
WEIGHT	kg/m	11.347
DRAWING No.	SECTION No.	
P-16070	-	
S5001	S5001	

1. ALL DIMENSIONS ARE IN mm.
2. ROUND OFF ALL SHARP CORNERS WITH 0.40 mm.
3. TOLERANCES WILL BE AS PER IS:3965-1981, UNLESS OTHERWISE SPECIFIED

PARTY'S NAME	OBLUM ELECTRICAL INDUSTRIES PVT. LTD., HYDERABAD
PARTY'S DRAWING No.	PBC-T8-TBC2-D8430-P
ALLOY & TEMPER	HE30 WP
DESCRIPTION	TERMINAL BLOCK SECTION