

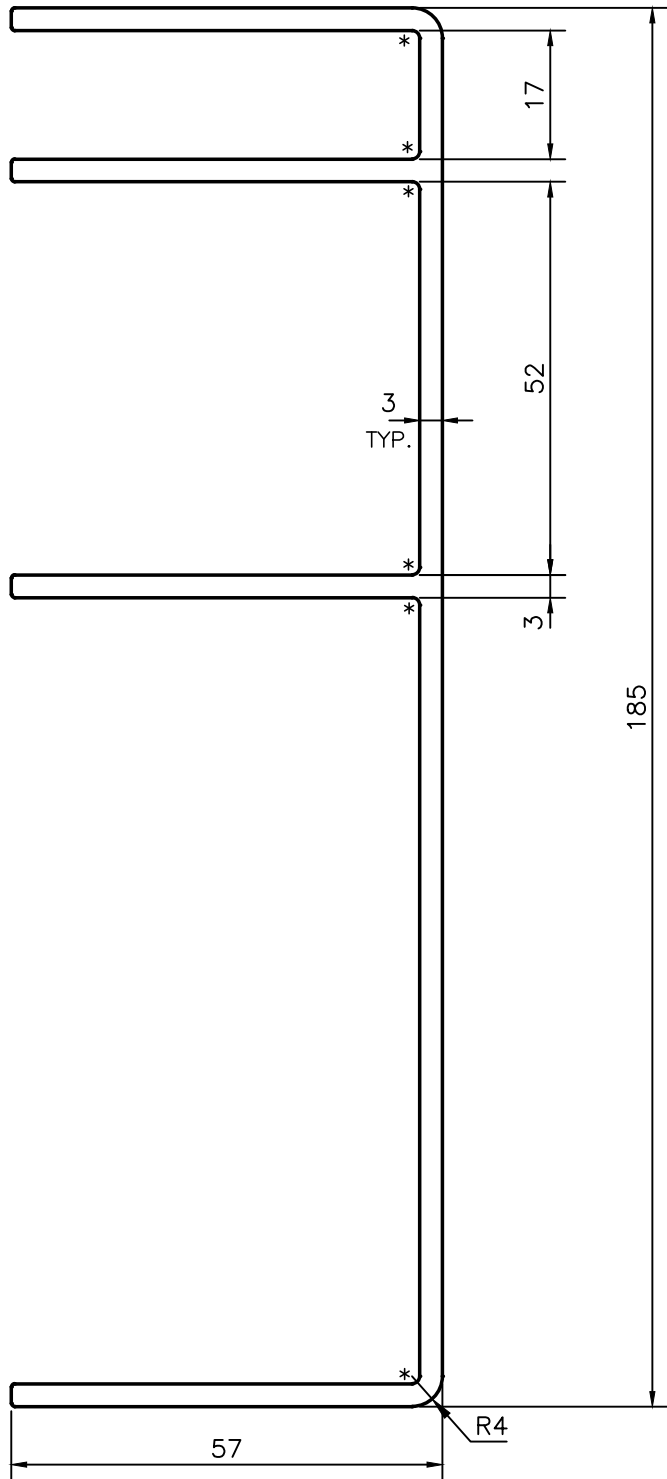

P-16062
S5005



 SYMBOL OF QUALITY AN ISO 9001 COMPANY	JINDAL ALUMINIUM LTD. BANGALORE-560073 (INDIA)	NAME		DATE
		DRAWN	J.P.KAUSHIK	02-07-2016
1. ALL DIMENSIONS ARE IN mm. 2. ROUND OFF ALL SHARP CORNERS WITH 0.40 mm. 3. TOLERANCES WILL BE AS PER IS:3965-1981 , UNLESS OTHERWISE SPECIFIED		CHECKED		
		APPROVED	S.S. GARG	11-07-2016
PARTY'S NAME PRESSTON ENGINEERING CORPORATION, BANGALORE		SCALE		1:1
		AREA mm ²		1197.146
PARTY'S DRAWING No. AS PER DRAWING		PERIMETER mm.		800.618
		WEIGHT kg/m		3.232
ALLOY & TEMPER 6063 T5		DRAWING No.		SECTION No.
		P-16062		-
DESCRIPTION CABLE TRAY SECTION		S5005		S5005