

P-16026

S5025

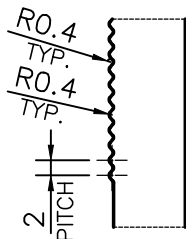
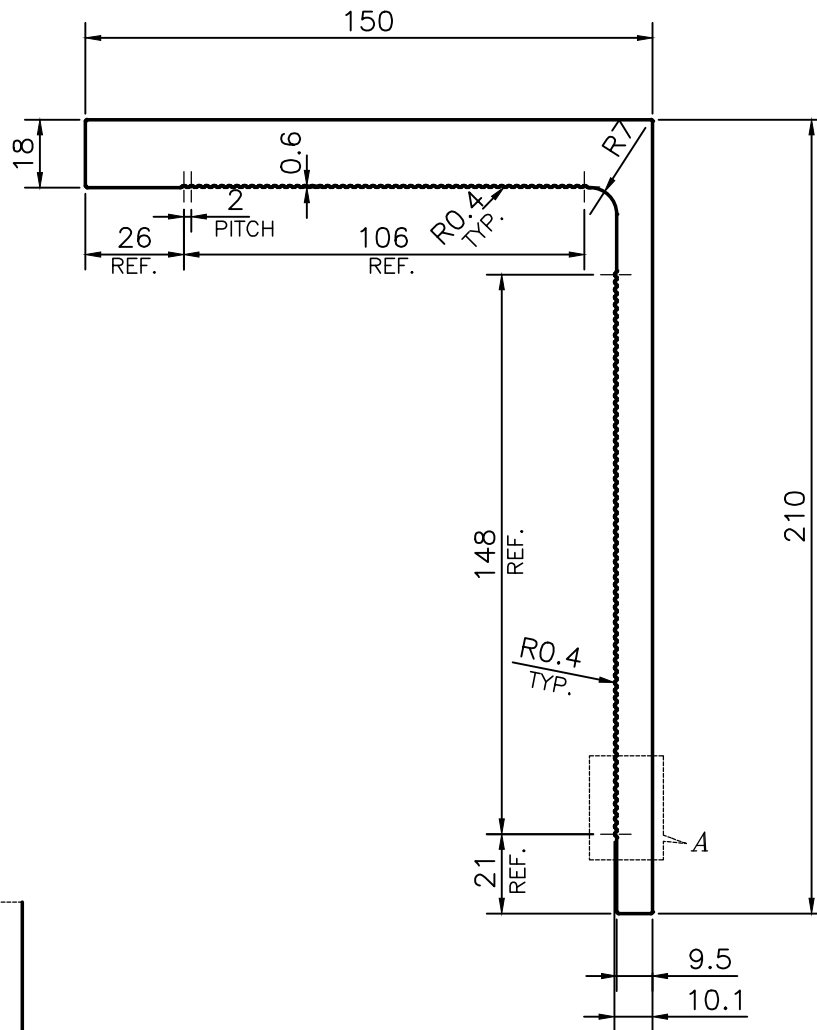

DETAIL OF "A"
SCALE 1:1

TOLERANCES ON OVERALL WIDTHS & WIDTHS ACROSS FLATS OF BARS, & REGULAR SECTIONS

| | | | |
|---------------------|----------------------|----------------------|---|
| UPTO 6.40mm - ±0.20 | UPTO 32.0mm - ±0.38 | UPTO 120.0mm - ±0.85 | 1. STRAIGHTNESS=1.7mm/M 2. TWIST=1.7mm/M 3. ANGULARITY= ±2° 4. FLATNESS =0.007xWIDTH |
| UPTO 10.0mm - ±0.23 | UPTO 50.0mm - ±0.46 | UPTO 160.0mm - ±1.02 | |
| UPTO 12.0mm - ±0.25 | UPTO 60.0mm - ±0.53 | UPTO 200.0mm - ±1.14 | |
| UPTO 16.0mm - ±0.28 | UPTO 80.0mm - ±0.69 | UPTO 250.0mm - ±1.40 | |
| UPTO 25.0mm - ±0.30 | UPTO 100.0mm - ±0.75 | UPTO 300.0mm - ±1.65 | |
| | | | |

| | | | |
|---|--|----------------------|-------------|
|  SYMBOL OF QUALITY AN ISO 9001 COMPANY | JINDAL ALUMINIUM LTD. BANGALORE-560073 (INDIA) | NAME | DATE |
| | | DRAWN | PARVESH |
| | | CHECKED | |
| | | APPROVED | S.S. GARG |
| | | | 11-07-2016 |
| 1. ALL DIMENSIONS ARE IN mm. 2. ROUND OFF ALL SHARP CORNERS WITH 0.40 mm. 3. TOLERANCES WILL BE AS PER IS:3965-1981, UNLESS OTHERWISE SPECIFIED | | SCALE | 0.5:1 |
| | | AREA mm ² | 4546.944 |
| | | PERIMETER mm. | 766.706 |
| | | WEIGHT kg/m | 12.277 |
| PARTY'S NAME | AHLUWALIA CONTRACTS (INDIA) LTD., MUMBAI | DRAWING No. | SECTION No. |
| PARTY'S DRAWING No. | AS PER AUTOCAD DRAWING | P-16026 | - |
| ALLOY & TEMPER | 6005 T6 | S5025 | S5025 |
| DESCRIPTION | CURTAIN WALL SECTION-UNEQUAL ANGLE | | |