

P-16028

S5027

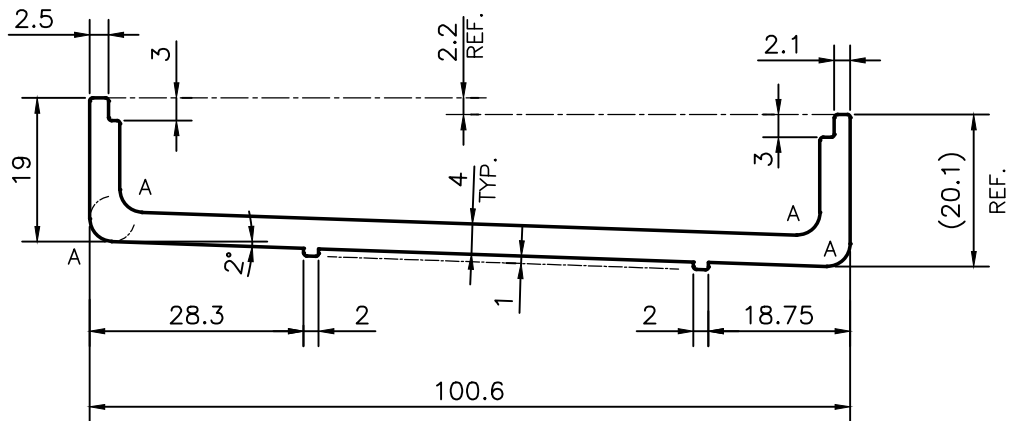

A = RADIUS 3 mm. (4 PLACES)

TOLERANCES ON OVERALL WIDTHS & WIDTHS ACROSS FLATS OF BARS, & REGULAR SECTIONS

UPTO 6.40mm - ±0.20	UPTO 32.0mm - ±0.38	UPTO 120.0mm - ±0.85	1. STRAIGHTNESS=1.7mm/M 2. TWIST=1.7mm/M 3. ANGULARITY= ±2° 4. FLATNESS =0.007xWIDTH
UPTO 10.0mm - ±0.23	UPTO 50.0mm - ±0.46	UPTO 160.0mm - ±1.02	
UPTO 12.0mm - ±0.25	UPTO 60.0mm - ±0.53	UPTO 200.0mm - ±1.14	
UPTO 16.0mm - ±0.28	UPTO 80.0mm - ±0.69	UPTO 250.0mm - ±1.40	
UPTO 25.0mm - ±0.30	UPTO 100.0mm - ±0.75	UPTO 300.0mm - ±1.65	

 SYMBOL OF QUALITY AN ISO 9001 COMPANY	JINDAL ALUMINIUM LTD. BANGALORE-560073 (INDIA)	NAME	DATE
		DRAWN	PARVESH
		CHECKED	
		APPROVED	S.S. GARG
			11-07-2016
1. ALL DIMENSIONS ARE IN mm. 2. ROUND OFF ALL SHARP CORNERS WITH 0.40 mm. 3. TOLERANCES WILL BE AS PER IS:3965-1981 , UNLESS OTHERWISE SPECIFIED		SCALE	1:1
		AREA mm ²	520.582
		PERIMETER mm.	268.302
		WEIGHT kg/m	1.406
PARTY'S NAME	AHLUWALIA CONTRACTS (INDIA) LTD., MUMBAI	DRAWING No.	SECTION No.
PARTY'S DRAWING No.	AS PER AUTOCAD DRAWING	P-16028	-
ALLOY & TEMPER	6063 T6	S5027	S5027
DESCRIPTION	CURTAIN WALL SECTION		