

P-15650

S5041

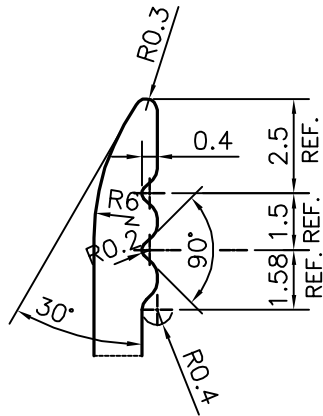

DETAIL OF "A"
SCALE 5:1

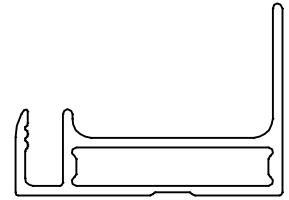

SCALE: - 1:1

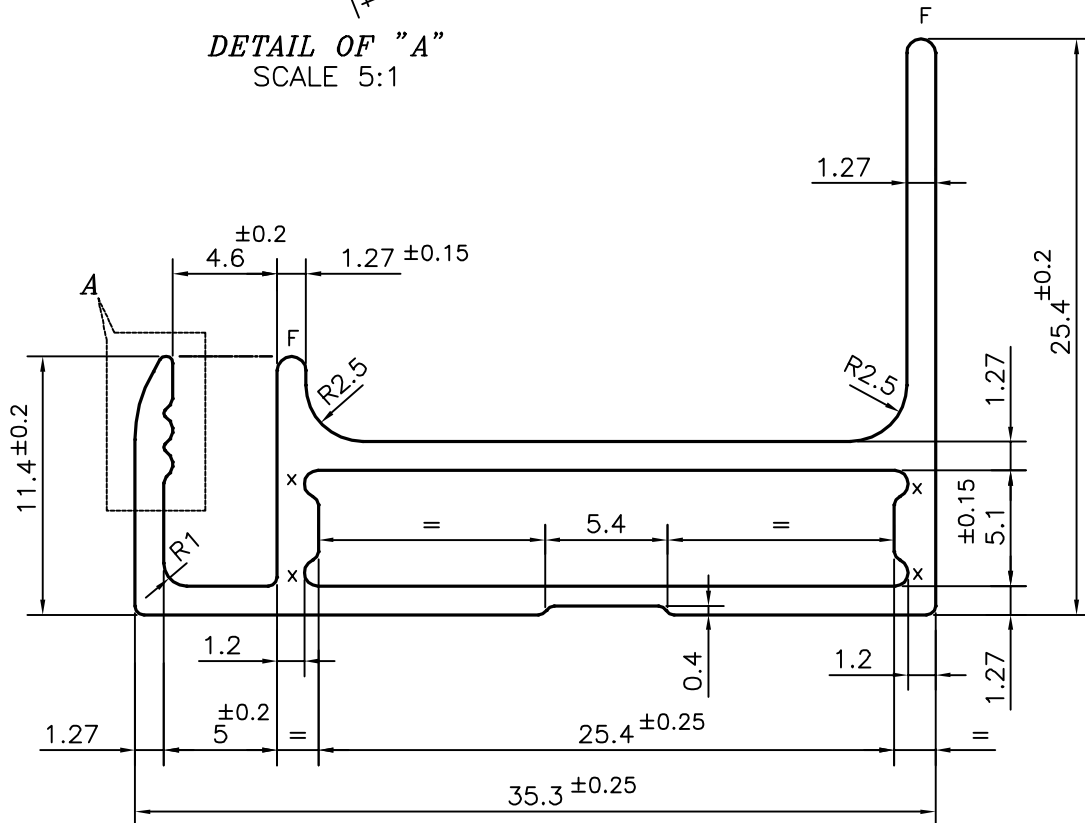

F = FULL RADIUS (2 PLACES)
X = RADIUS 0.6 mm. (4 PLACES)



SYMBOL OF QUALITY
AN ISO 9001 COMPANY

JINDAL ALUMINIUM LTD.
BANGALORE-560073 (INDIA)

	NAME	DATE
DRAWN	PARVESH	10-03-2016
CHECKED		
APPROVED	S.S. GARG	21-07-2016

1. ALL DIMENSIONS ARE IN mm.
2. ROUND OFF ALL SHARP CORNERS WITH 0.40 mm.
3. TOLERANCES WILL BE AS PER IS:6477-1983, UNLESS OTHERWISE SPECIFIED

SCALE	3:1
AREA mm ²	138.542
PERIMETER mm.	145.269
WEIGHT kg/m	0.374

PARTY'S NAME ALEENA SOLAR PVT. LTD., KOLKATA

PARTY'S DRAWING No. MODIFIED OF SECTION No. S4483

ALLOY & TEMPER 6063 T6

DESCRIPTION SOLAR SECTION

DRAWING No.	SECTION No.
P-15650	-
S5041	S5041