

P-16057

S5059

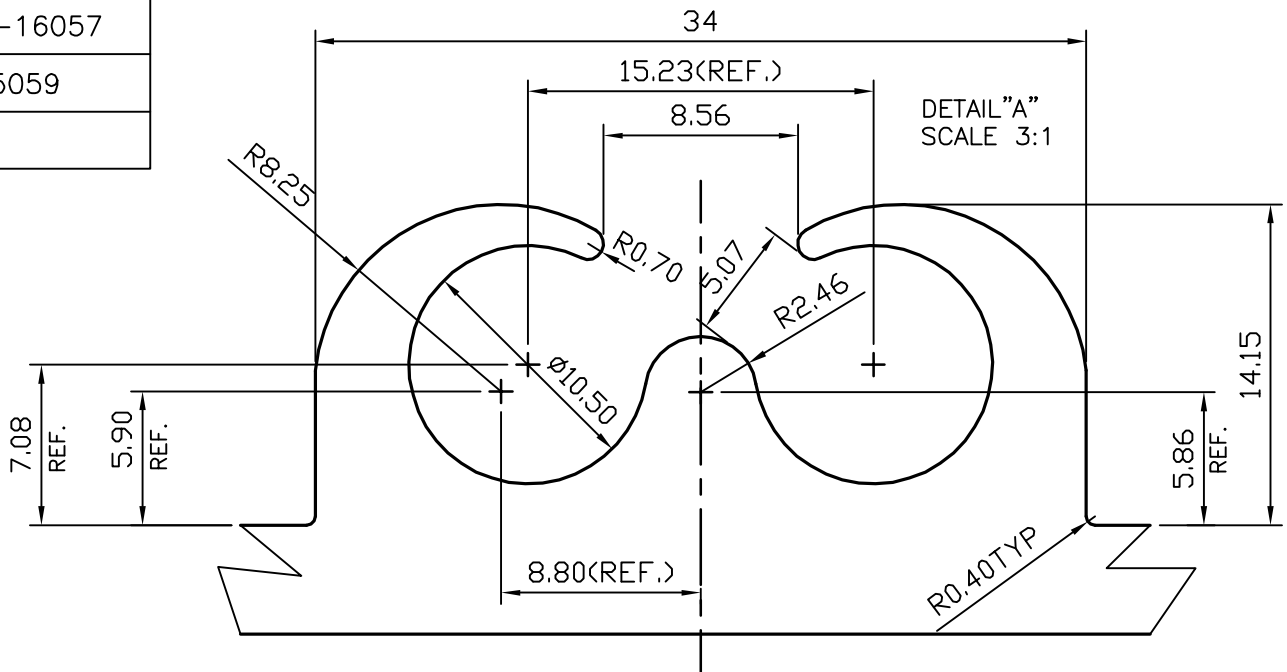

DETAIL "A"

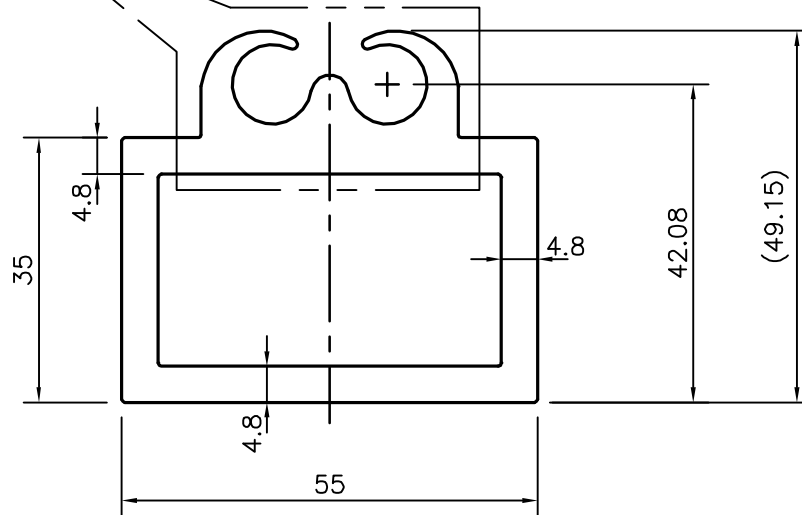

SYMBOL OF QUALITY  
AN ISO 9001 COMPANY

**JINDAL ALUMINIUM LTD.**  
BANGALORE-560073 (INDIA)

	NAME	DATE
DRAWN	J.P.KAUSHIK	01-07-2016
CHECKED		
APPROVED	S.S. GARG	11-08-2016

1. ALL DIMENSIONS ARE IN mm.
2. ROUND OFF ALL SHARP CORNERS WITH 0.40 mm.
3. TOLERANCES WILL BE AS PER IS:6477-1983 UNLESS OTHERWISE SPECIFIED

SCALE	1:1
AREA mm <sup>2</sup>	1000.66
PERIMETER mm.	255.315
WEIGHT kg/m	2.702

PARTY'S NAME	AUTOMOTIVE COACHES & COMPONENTS LTD., CHENNAI
PARTY'S DRAWING No.	AS PER DRAWING
ALLOY & TEMPER	6005 T6
DESCRIPTION	MISC. SECTION

DRAWING No.	SECTION No.
P-16057	-
S5059	S5059