

P-15911

S5069

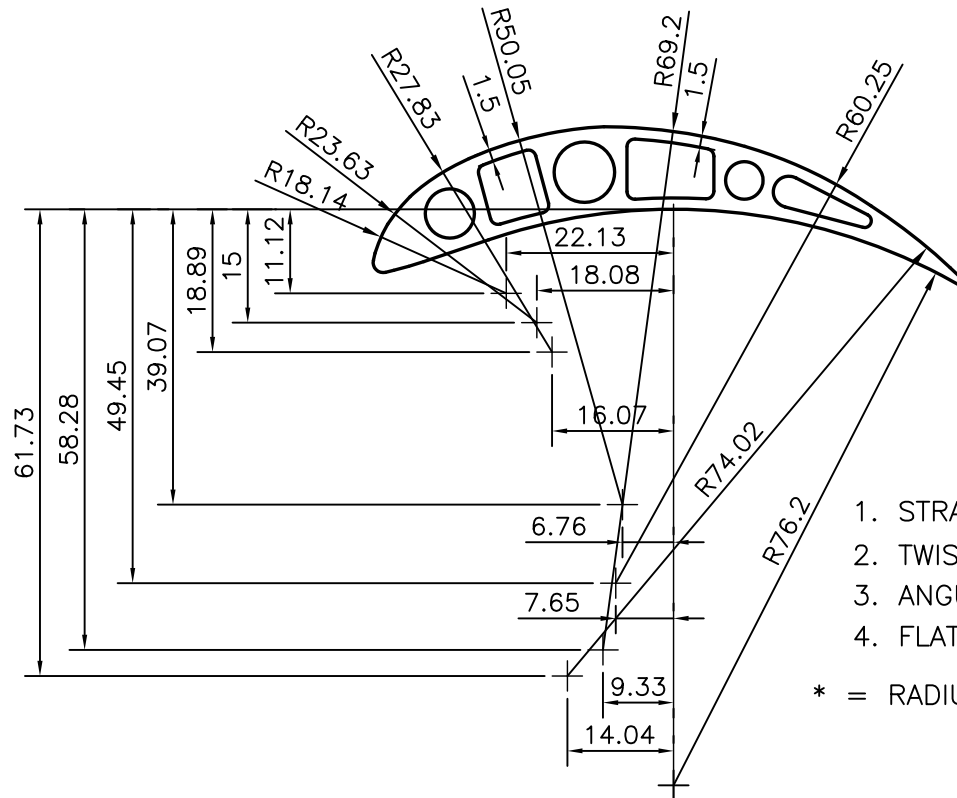
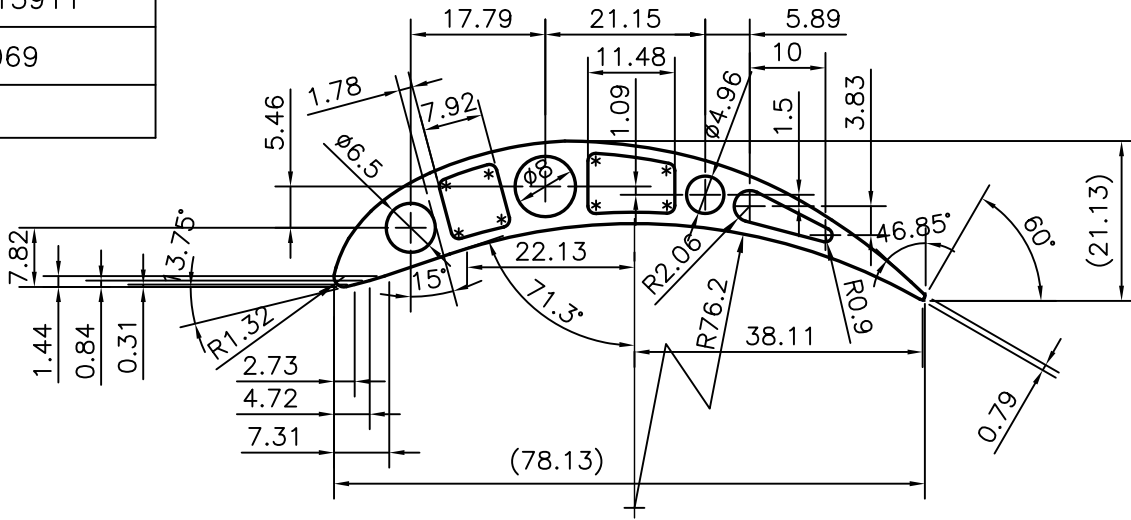

- 1. STRAIGHTNESS=1.7mm/M
- 2. TWIST=1.7mm/M
- 3. ANGULARITY= ±2°
- 4. FLATNESS =0.3mm

\* = RADIUS R1.00 (8 PLACES)

TOLERANCES ON OVERALL WIDTHS & WIDTHS ACROSS FLATS OF BARS, & REGULAR SECTIONS

UPTO 6.40mm - ±0.20	UPTO 32.0mm - ±0.38	UPTO 120.0mm - ±0.85	UPTO 320.00mm - ±1.70
UPTO 10.0mm - ±0.23	UPTO 50.0mm - ±0.46	UPTO 160.0mm - ±1.02	
UPTO 12.0mm - ±0.25	UPTO 60.0mm - ±0.53	UPTO 200.0mm - ±1.14	
UPTO 16.0mm - ±0.28	UPTO 80.0mm - ±0.69	UPTO 250.0mm - ±1.40	
UPTO 25.0mm - ±0.30	UPTO 100.0mm - ±0.75	UPTO 300.0mm - ±1.65	



SYMBOL OF QUALITY  
AN ISO 9001 COMPANY

**JINDAL ALUMINIUM LTD.**  
BANGALORE-560073 (INDIA)

	NAME	DATE
DRAWN	RACHAVENDRA	03-06-2016
CHECKED		
APPROVED	S.S.GARG	25-08-2016

- 1. ALL DIMENSIONS ARE IN mm.
- 2. ROUND OFF ALL SHARP CORNERS WITH 0.40 mm.
- 3. TOLERANCES WILL BE AS PER IS:6477-1983, UNLESS OTHERWISE SPECIFIED

SCALE	1:1
AREA mm <sup>2</sup>	382.378
PERIMETER mm.	173.287
WEIGHT kg/m	1.032

PARTY'S NAME	IMPEX ENGINEERING WORKS, HOWRAH
PARTY'S DRAWING No.	PART NO-8421882
ALLOY & TEMPER	6063 T5
DESCRIPTION	FAN BLADE SECTION

DRAWING No.	SECTION No.
P-15911	
S5069	S5069