

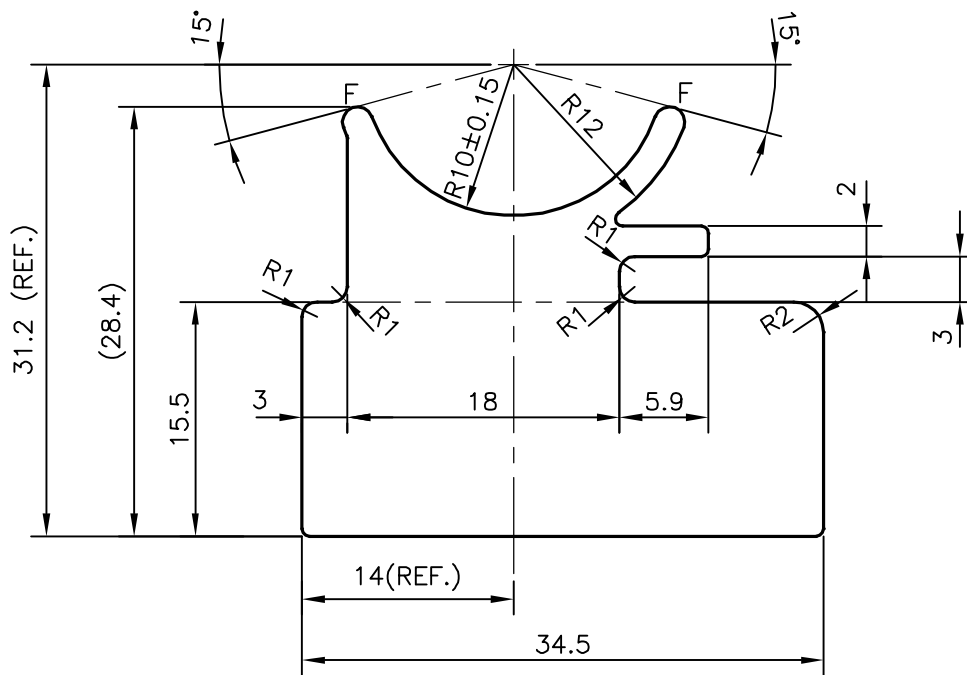

P-15876-1

S5084

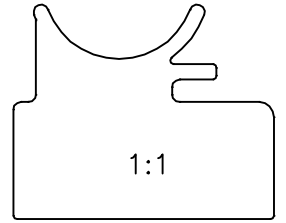

UNSPECIFIED RADIUS 0.5 mm

F = FULL RADIUS (2 PLACES)

 SYMBOL OF QUALITY AN ISO 9001 COMPANY	<b>JINDAL ALUMINIUM LTD.</b> BANGALORE-560073 (INDIA)	NAME		DATE
		DRAWN	J.P.KAUSHIK	16-08-2016
1. ALL DIMENSIONS ARE IN mm. 2. ROUND OFF ALL SHARP CORNERS WITH 0.40 mm. 3. TOLERANCES WILL BE AS PER IS:3965-1981 UNLESS OTHERWISE SPECIFIED		CHECKED		
		APPROVED		S.S. GARG
PARTY'S NAME WONJIN AUTOPARTS INDIA PVT. LTD., MARAMALAI NAGAR		SCALE		2:1
		AREA mm <sup>2</sup>		696.238
PARTY'S DRAWING No. AS PER AutoCAD DRAWING-PLF742HWFAB01 000		PERIMETER mm.		145.866
		WEIGHT kg/m		1.880
ALLOY & TEMPER 6005 T5		DRAWING No.		P-15876-1
		SECTION No.		-
DESCRIPTION JOINT FLANGE SECTION		S5084		S5084