

P-16153-1

S5085

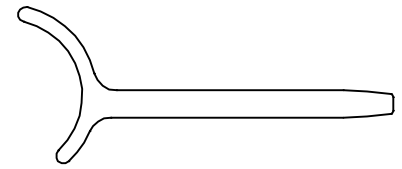

SCALE 1:1

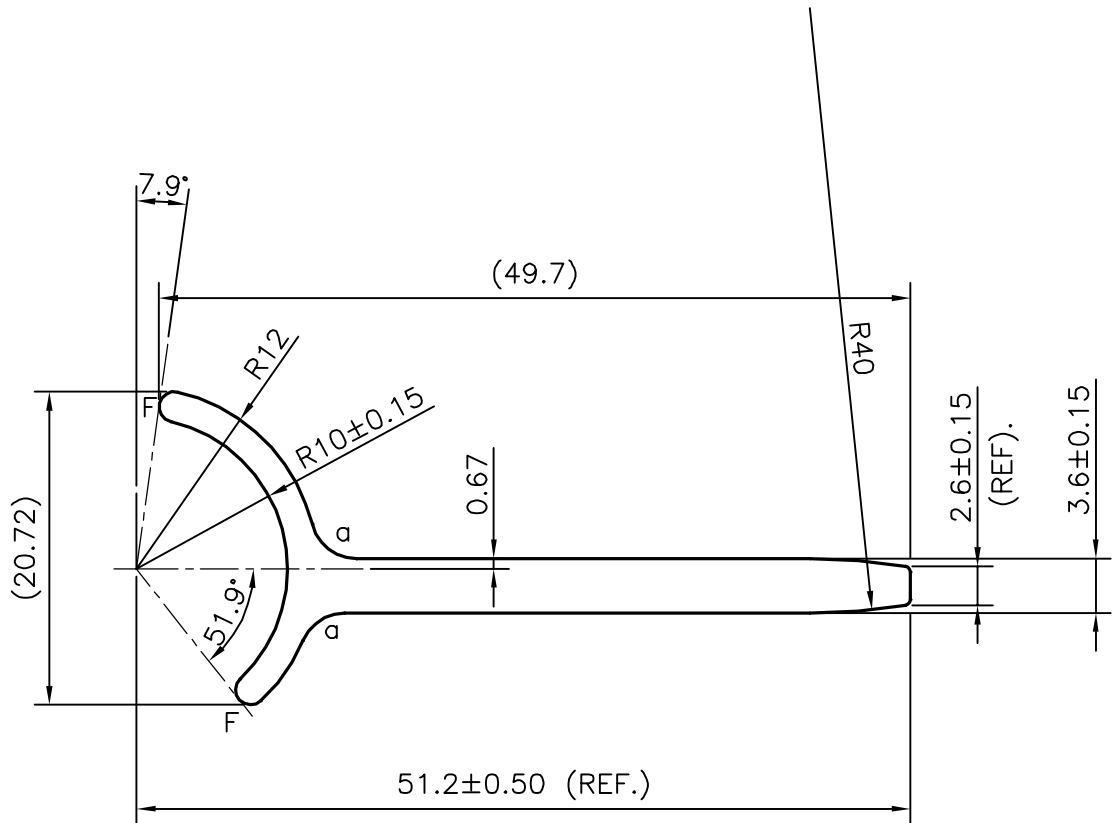

a=RADIUS 3.0 (2 PLACES)

F=FULL RADIUS (2 PLACES)



SYMBOL OF QUALITY  
AN ISO 9001 COMPANY

**JINDAL ALUMINIUM LTD.**  
BANGALORE-560073 (INDIA)

	NAME	DATE
DRAWN	KIRAN	12-08-2016
CHECKED		
APPROVED	S.S. GARG	24-09-2016
SCALE		2:1
AREA mm <sup>2</sup>		191.545
PERIMETER mm.		129.738
WEIGHT kg/m		0.517
DRAWING No.	SECTION No.	
P-16153-1	-	
S5085	S5085	

1. ALL DIMENSIONS ARE IN mm.
2. ROUND OFF ALL SHARP CORNERS WITH 0.40 mm.
3. TOLERANCES WILL BE AS PER IS:3965-1981, UNLESS OTHERWISE SPECIFIED

PARTY'S NAME	WONJIN AUTOPARTS INDIA PVT.LTD., CHENNAI
PARTY'S DRAWING No.	00317047-01
ALLOY & TEMPER	6005 T5
DESCRIPTION	BRKT TOC-COMBO COOLER