

P-16379

S5088

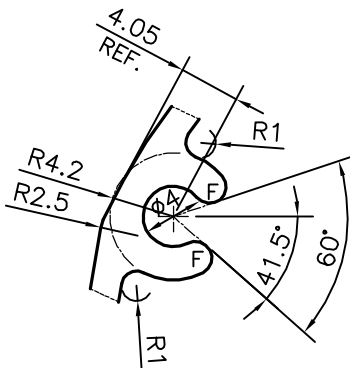
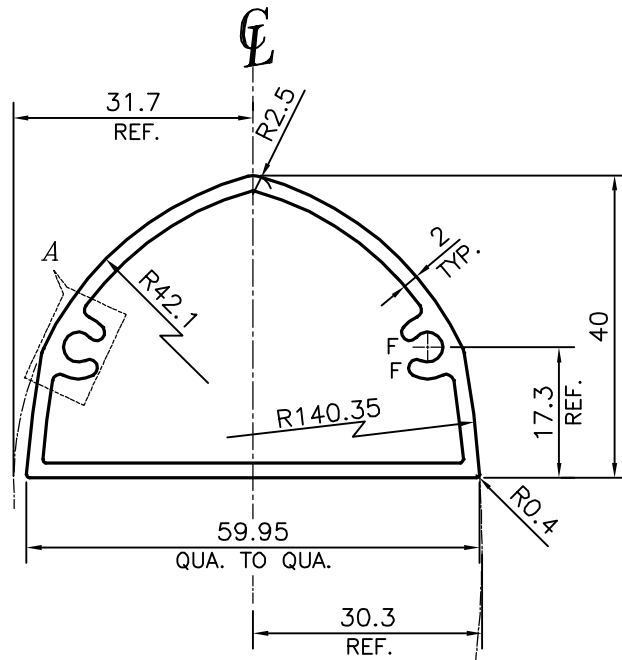

DETAIL OF "A"
SCALE 2:1

F = FULL RADIUS (4 PLACES)



SYMBOL OF QUALITY
AN ISO 9001 COMPANY

JINDAL ALUMINIUM LTD.
BANGALORE-560073 (INDIA)

	NAME	DATE
DRAWN	PARVESH	20-09-2016
CHECKED		
APPROVED	S.S. GARG	24-09-2016
SCALE		1:1
AREA mm ²		370.735
PERIMETER mm.		168.581
WEIGHT kg/m		1.001
DRAWING No.	SECTION No.	
P-16379	-	
S5088	S5088	

1. ALL DIMENSIONS ARE IN mm.
2. ROUND OFF ALL SHARP CORNERS WITH 0.40 mm.
3. TOLERANCES WILL BE AS PER IS:6477-1983 , UNLESS OTHERWISE SPECIFIED

PARTY'S NAME	MARVEL TOUCH ALUMINIUM PVT. LTD., MUMBAI
PARTY'S DRAWING No.	AS PER AUTOCAD DRAWING-FIN(B)
ALLOY & TEMPER	6063 T6
DESCRIPTION	LOUVER SECTION