

P-16435-1

S5113

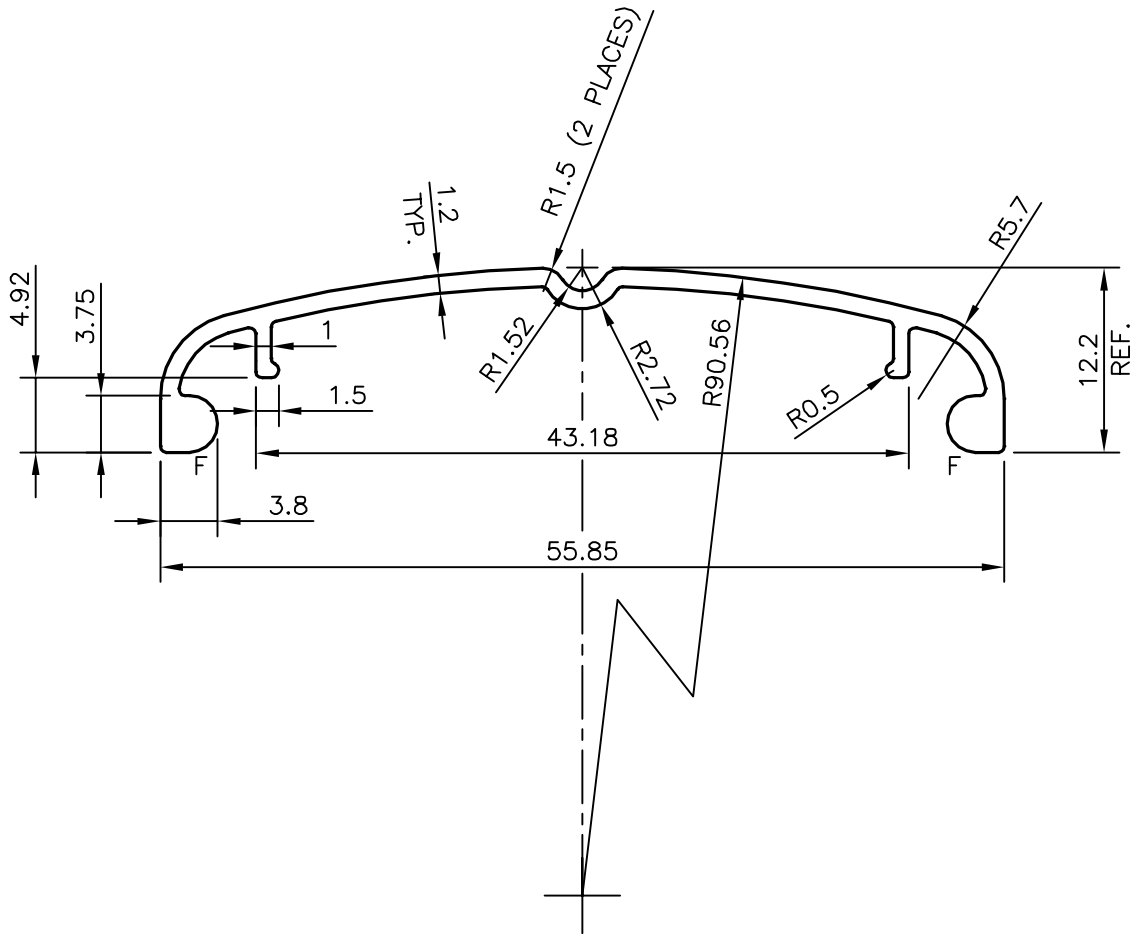

SCALE 1:1



F : FULL RADIUS (2 PLACES)



SYMBOL OF QUALITY
AN ISO 9001 COMPANY

JINDAL ALUMINIUM LTD.
BANGALORE-560073 (INDIA)

	NAME	DATE
DRAWN	KIRAN	07-10-2016
CHECKED		
APPROVED	B.NATARAJ	17-10-2016
SCALE		2:1
AREA mm ²		107.486
PERIMETER mm.		161.02
WEIGHT kg/m		0.290
DRAWING No.	SECTION No.	
P-16435-1		
S5113	S5113	

1. ALL DIMENSIONS ARE IN mm.
2. ROUND OFF ALL SHARP CORNERS WITH 0.40 mm.
3. TOLERANCES WILL BE AS PER IS:3965-1981, UNLESS OTHERWISE SPECIFIED

PARTY'S NAME	XINDO WINDOW PVT. LTD., CHENNAI
PARTY'S DRAWING No.	AS PER AutoCAD DRAWING & REQUIREMENT
ALLOY & TEMPER	HE9 WP
DESCRIPTION	WINDOW MISC. SECTION