

P-16429

S5119

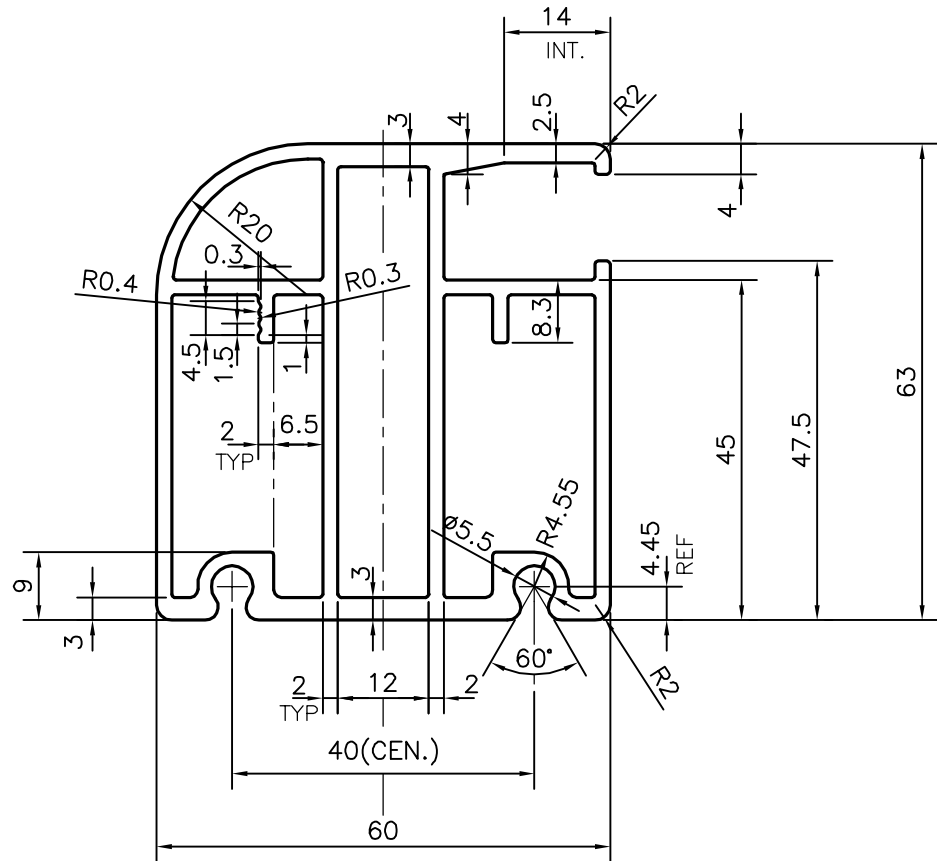

SYMBOL OF QUALITY
AN ISO 9001 COMPANY

JINDAL ALUMINIUM LTD.
BANGALORE-560073 (INDIA)

	NAME	DATE
DRAWN	J.P.KAUSHIK	04-10-2016
CHECKED		
APPROVED	B.NATARAJ	21-10-2016

1. ALL DIMENSIONS ARE IN mm.
2. ROUND OFF ALL SHARP CORNERS WITH 0.40 mm.
3. TOLERANCES WILL BE AS PER,IS:6477-1983 UNLESS OTHERWISE SPECIFIED

SCALE	1:1
AREA mm ²	903.172
PERIMETER mm.	309.678
WEIGHT kg/m	2.439

PARTY'S NAME	MEGAVENT TECHNOLOGIES PVT LTD, BANGALORE
PARTY'S DRAWING No.	AS PER SAMPLE
ALLOY & TEMPER	6060 T6
DESCRIPTION	MISC. SECTION

DRAWING No.	SECTION No.
P-16429	-
S5119	S5119