

P-16456

S5123

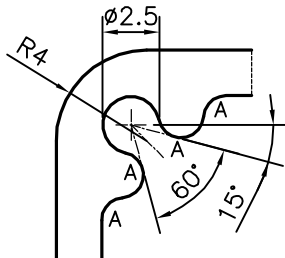
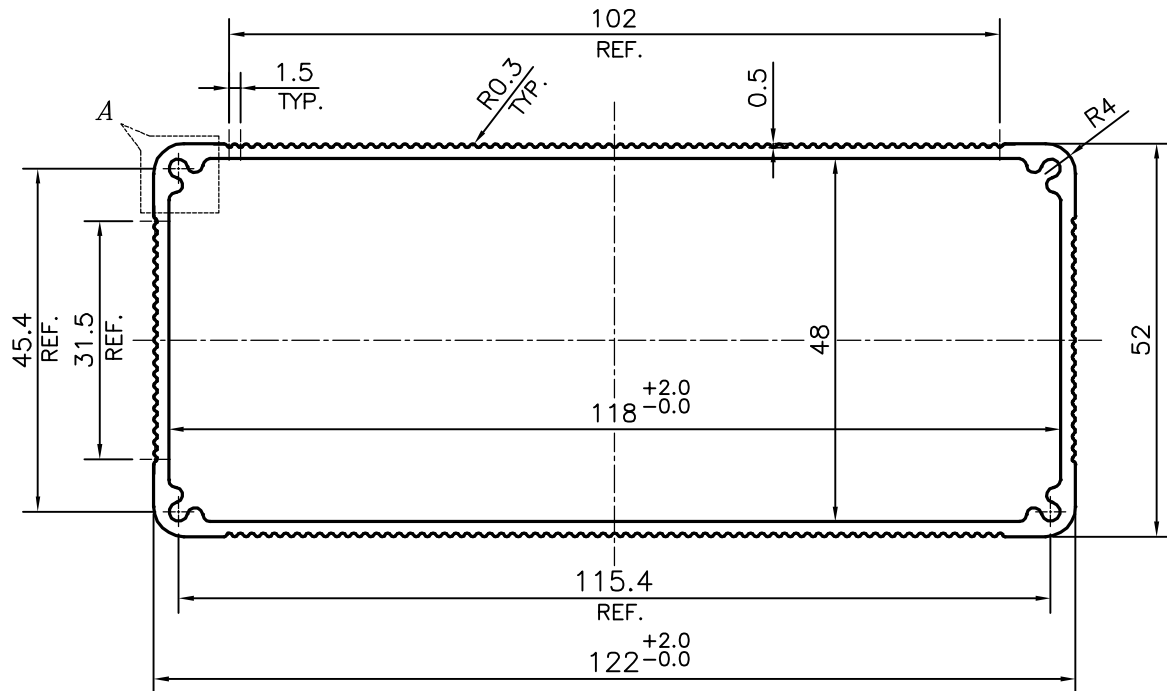

DETAIL OF "A"  
SCALE 3:1

A = RADIUS 1 mm. 16 PLACES)

TOLERANCES ON OVERALL WIDTHS & WIDTHS ACROSS FLATS OF BARS, & REGULAR SECTIONS

UPTO 6.40mm - ±0.20	UPTO 32.0mm - ±0.38	UPTO 120.0mm - ±0.85	1. STRAIGHTNESS=1.7mm/M 2. TWIST=1.7mm/M 3. ANGULARITY= ±2° 4. FLATNESS =0.007xWIDTH
UPTO 10.0mm - ±0.23	UPTO 50.0mm - ±0.46	UPTO 160.0mm - ±1.02	
UPTO 12.0mm - ±0.25	UPTO 60.0mm - ±0.53	UPTO 200.0mm - ±1.14	
UPTO 16.0mm - ±0.28	UPTO 80.0mm - ±0.69	UPTO 250.0mm - ±1.40	
UPTO 25.0mm - ±0.30	UPTO 100.0mm - ±0.75	UPTO 300.0mm - ±1.65	

 SYMBOL OF QUALITY AN ISO 9001 COMPANY	<b>JINDAL ALUMINIUM LTD.</b> BANGALORE-560073 (INDIA)	NAME	DATE
		DRAWN	PARVESH
		CHECKED	
		APPROVED	B. NATRAJ
			21-10-2016
1. ALL DIMENSIONS ARE IN mm. 2. ROUND OFF ALL SHARP CORNERS WITH 0.40 mm. 3. TOLERANCES WILL BE AS PER IS:6477-1983, UNLESS OTHERWISE SPECIFIED		SCALE	1:1
		AREA mm <sup>2</sup>	630.855
		PERIMETER mm.	407.326
		WEIGHT kg/m	1.703
PARTY'S NAME	GALLANT ELECTRONIC CONTROLS, BANGALORE	DRAWING No.	SECTION No.
PARTY'S DRAWING No.	AS PER DRAWING & REQUIREMENT	P-16456	-
ALLOY & TEMPER	6063 T6	S5123	S5123
DESCRIPTION	ELECTRICAL SECTION		