

P-16433

S5124

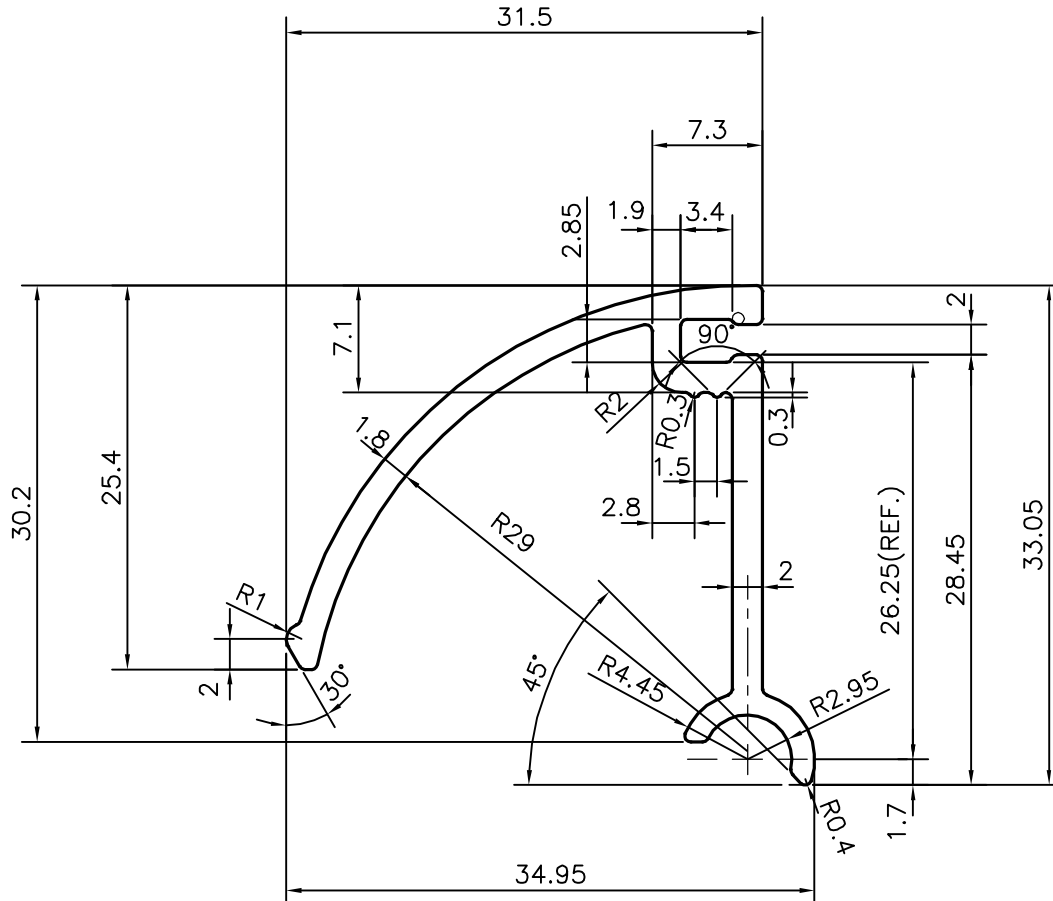
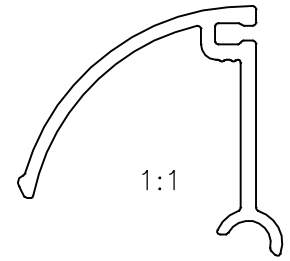
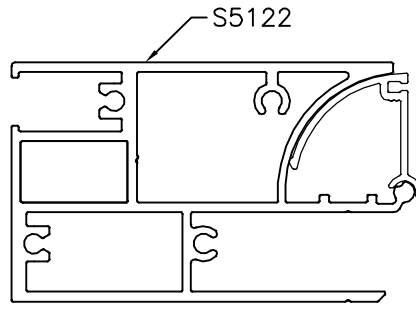

SYMBOL OF QUALITY  
AN ISO 9001 COMPANY

**JINDAL ALUMINIUM LTD.**  
BANGALORE-560073 (INDIA)

	NAME	DATE
DRAWN	J.P.KAUSHIK	07-10-2016
CHECKED		
APPROVED	B.NATARAJ	21-10-2016

1. ALL DIMENSIONS ARE IN mm.
2. ROUND OFF ALL SHARP CORNERS WITH 0.40 mm.
3. TOLERANCES WILL BE AS PER,IS:3965-1981 UNLESS OTHERWISE SPECIFIED

SCALE	2:1
AREA mm <sup>2</sup>	157.446
PERIMETER mm.	170.158
WEIGHT kg/m	0.425

PARTY'S NAME	MEGAVENT TECHNOLOGIES PVT LTD, BANGALORE
PARTY'S DRAWING No.	AS PER SAMPLE
ALLOY & TEMPER	6060 T6
DESCRIPTION	MISC. SECTION

DRAWING No.	SECTION No.
P-16433	-
S5124	S5124