

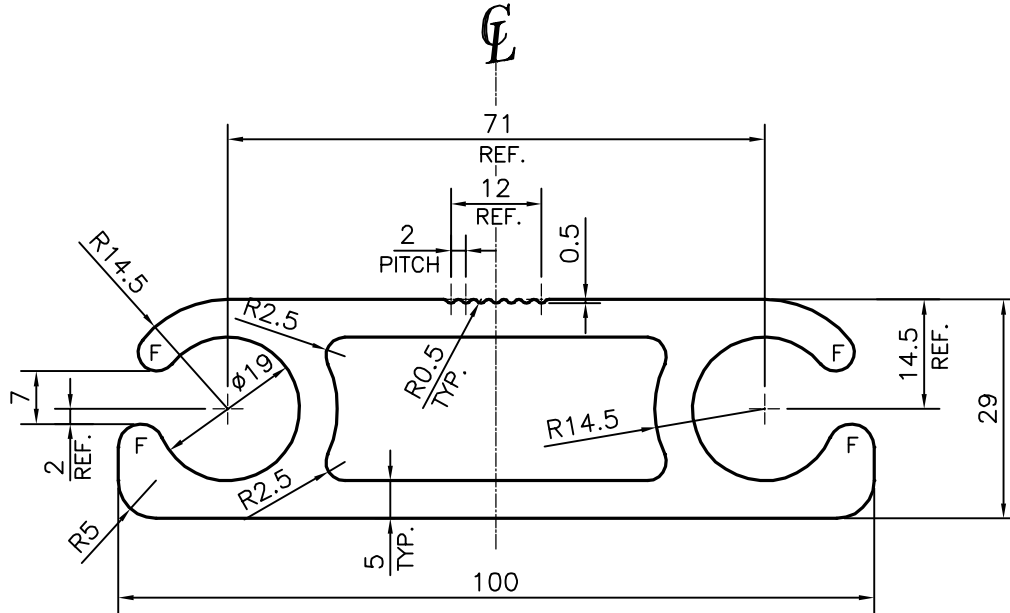

P-16539

S5184



F = FULL RADIUS (4 PLACES)

|   |  |                      |             |            |      |
|---|--|----------------------|-------------|------------|------|
| <br>SYMBOL OF QUALITY<br>AN ISO 9001 COMPANY | <b>JINDAL ALUMINIUM LTD.</b><br>BANGALORE-560073 (INDIA) |                      |             | NAME       | DATE |
|   |  | DRAWN                | PARVESH     | 18-11-2016 |      |
|   |  | CHECKED              |             |            |      |
|   |  | APPROVED             | B.NATARAJA  | 22-11-2016 |      |
|   |  | SCALE                |             | 1:1        |      |
|   |  | AREA mm <sup>2</sup> |             | 1317.576   |      |
|   |  | PERIMETER mm.        |             | 344.571    |      |
|   |  | WEIGHT kg/m          |             | 3.557      |      |
| PARTY'S NAME  | SREE BHARAT KIRAYA BHANDAR, RAIPUR                       | DRAWING No.          | SECTION No. |            |      |
| PARTY'S DRAWING No.   | AS PER DRAWING   | P-16539              | -           |            |      |
| ALLOY & TEMPER  | 6005 T6  | S5184                | S5184       |            |      |
| DESCRIPTION   | DISPLAY SECTION  |                      |             |            |      |