

P-14736-1

S5190

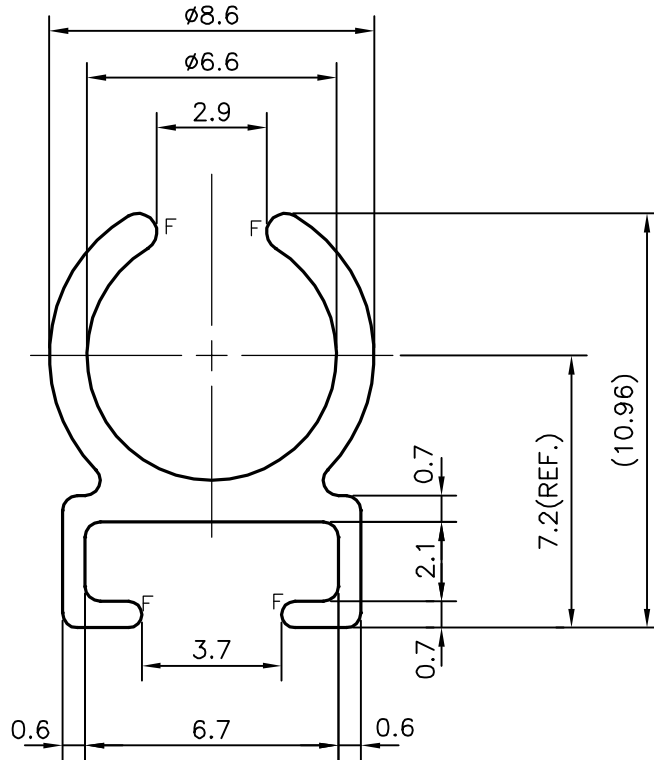

F = FULL RADIUS (4 PLACES)



SYMBOL OF QUALITY
AN ISO 9001 COMPANY

JINDAL ALUMINIUM LTD.
BANGALORE-560073 (INDIA)

| | NAME | DATE |
|----------------------|-------------|------------|
| DRAWN | J.P.KAUSHIK | 19-06-2015 |
| CHECKED | | |
| APPROVED | B.NATARAJ | 26-11-2016 |
| SCALE | | 5:1 |
| AREA mm ² | | 30.145 |
| PERIMETER mm. | | 63.5 |
| WEIGHT kg/m | | 0.081 |
| DRAWING No. | SECTION No. | |
| P-14736-1 | | |
| S5190 | S5190 | |
| | | |
| | | |

1. ALL DIMENSIONS ARE IN mm.
2. ROUND OFF ALL SHARP CORNERS WITH 0.40 mm.
3. TOLERANCES WILL BE AS PER IS:3965-1981 UNLESS OTHERWISE SPECIFIED

| | |
|---------------------|--------------------------------------------------|
| PARTY'S NAME | ACCUMAX INTERIOR PRODUCTS PVT. LTD., JAMNAGAR |
| PARTY'S DRAWING No. | AS PER SAMPLE |
| ALLOY & TEMPER | HE9 WP |
| DESCRIPTION | VENETIAN BLIND SECTION |