

P-16586

S5252

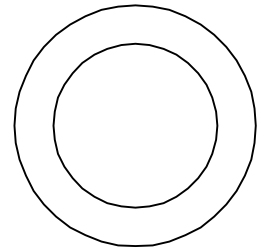

SCALE 1:1

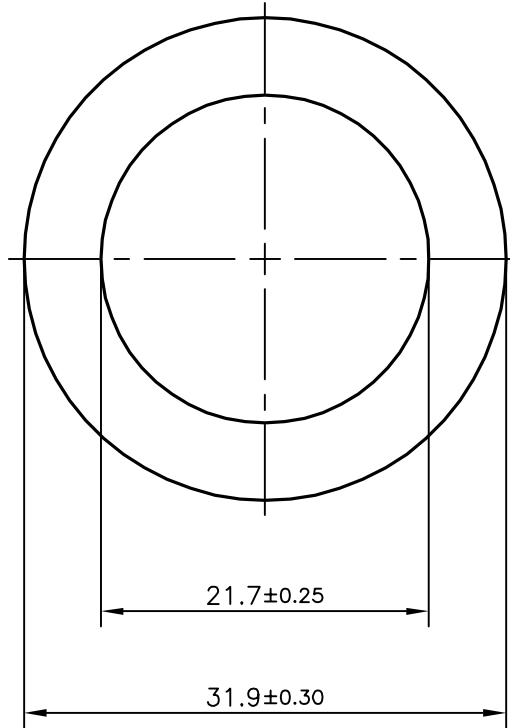

SYMBOL OF QUALITY
AN ISO 9001 COMPANY

JINDAL ALUMINIUM LTD.
BANGALORE-560073 (INDIA)

	NAME	DATE
DRAWN	KIRAN	03-12-2016
CHECKED		
APPROVED	B.NATARAJ	09-01-2017
SCALE		2:1
AREA mm ²		429.393
PERIMETER mm.		100.217
WEIGHT kg/m		1.159
DRAWING No.	SECTION No.	
P-16586		
S5252	S5252	

1. ALL DIMENSIONS ARE IN mm.
2. ROUND OFF ALL SHARP CORNERS WITH 0.50 mm.
3. TOLERANCES WILL BE AS PER IS:2673-2002, UNLESS OTHERWISE SPECIFIED

PARTY'S NAME	SWASTIKA AUTOMATICS, FARIDABAD
PARTY'S DRAWING No.	A21870970G
ALLOY & TEMPER	DA3103 BD'O'
DESCRIPTION	ROUND TUBE