

P-16752-2

S5278

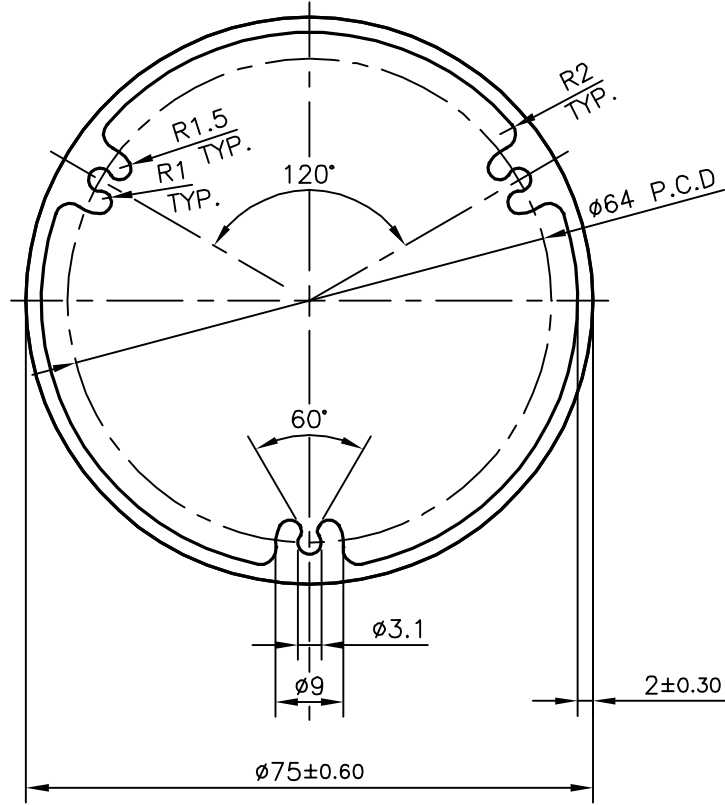

OVALITY : ±1.30 mm

TOLERANCES ON OVERALL DIMENSIONS OF HOLLOW SECTIONS

UPTO 20.0mm - ±0.30	UPTO 80.0mm - ±0.70	UPTO 180.0mm - ±1.27	1. STRAIGHTNESS=1.7mm/M 2. TWIST=1.7mm/M 3. ANGULARITY= ±2° 4. FLATNESS =0.006xWIDTH
UPTO 30.0mm - ±0.38	UPTO 100.0mm - ±0.80	UPTO 200.0mm - ±1.40	
UPTO 40.0mm - ±0.45	UPTO 120.0mm - ±0.90	UPTO 225.0mm - ±1.52	
UPTO 50.0mm - ±0.52	UPTO 140.0mm - ±1.00		
UPTO 60.0mm - ±0.60	UPTO 160.0mm - ±1.14		



SYMBOL OF QUALITY
AN ISO 9001 COMPANY

JINDAL ALUMINIUM LTD.
BANGALORE-560073 (INDIA)

	NAME	DATE
DRAWN	KIRAN	24-01-2017
CHECKED		
APPROVED	B.NATARAJ	27-01-2017
SCALE		1:1
AREA mm ²		595.358
PERIMETER mm.		235.619
WEIGHT kg/m		1.607
DRAWING No.		SECTION No.
P-16752-2		
S5278		S5278

1. ALL DIMENSIONS ARE IN mm.
2. ROUND OFF ALL SHARP CORNERS WITH 0.50 mm.
3. TOLERANCES WILL BE AS PER IS:6477-1983, UNLESS OTHERWISE SPECIFIED

PARTY'S NAME	JDIANM LIGHTING (P) LTD., VASAI
PARTY'S DRAWING No.	AS PER DRAWING & REQUIREMENT
ALLOY & TEMPER	HE9 WP
DESCRIPTION	TUBE LIGHT SECTION