

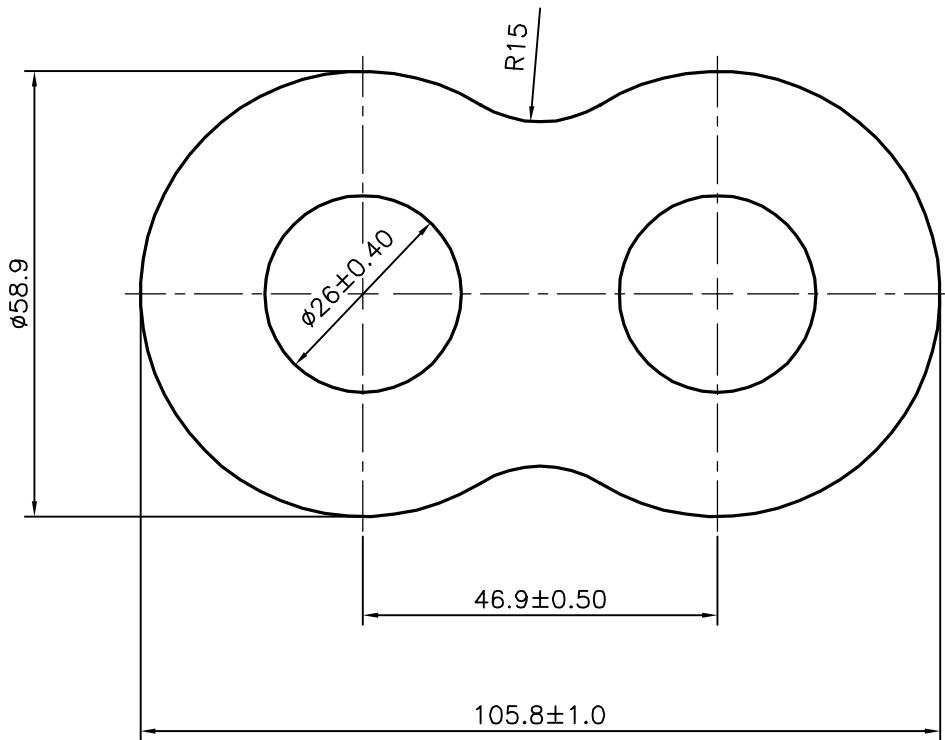

P-16813

S5317



 SYMBOL OF QUALITY AN ISO 9001 COMPANY	JINDAL ALUMINIUM LTD. <i>BANGALORE-560073 (INDIA)</i>		NAME	DATE
		DRAWN	J.P.KAUSHIK	10-02-2017
1. ALL DIMENSIONS ARE IN mm. 2. ROUND OFF ALL SHARP CORNERS WITH 0.40 mm. 3. TOLERANCES WILL BE AS PER IS:6477-1983 UNLESS OTHERWISE SPECIFIED		CHECKED		
		APPROVED	B.NATARAJ	04-03-2017
PARTY'S NAME SURFINE TOOLS, COIMBATORE		SCALE		1:1
		AREA mm ²		4147.735
PARTY'S DRAWING No. AS PER DRAWING-63000006-0002		PERIMETER mm.		283.848
		WEIGHT kg/m		11.199
ALLOY & TEMPER 6082 T6		DRAWING No.	SECTION No.	
		P-16813	-	
DESCRIPTION ACTUATOR BODY SECTION		S5317	S5317	