

P-16660

S5375

DETAIL OF "B"
SCALE 2:1

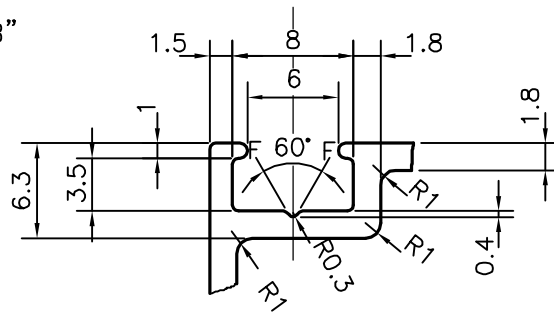

DETAIL OF "A"
SCALE 2:1

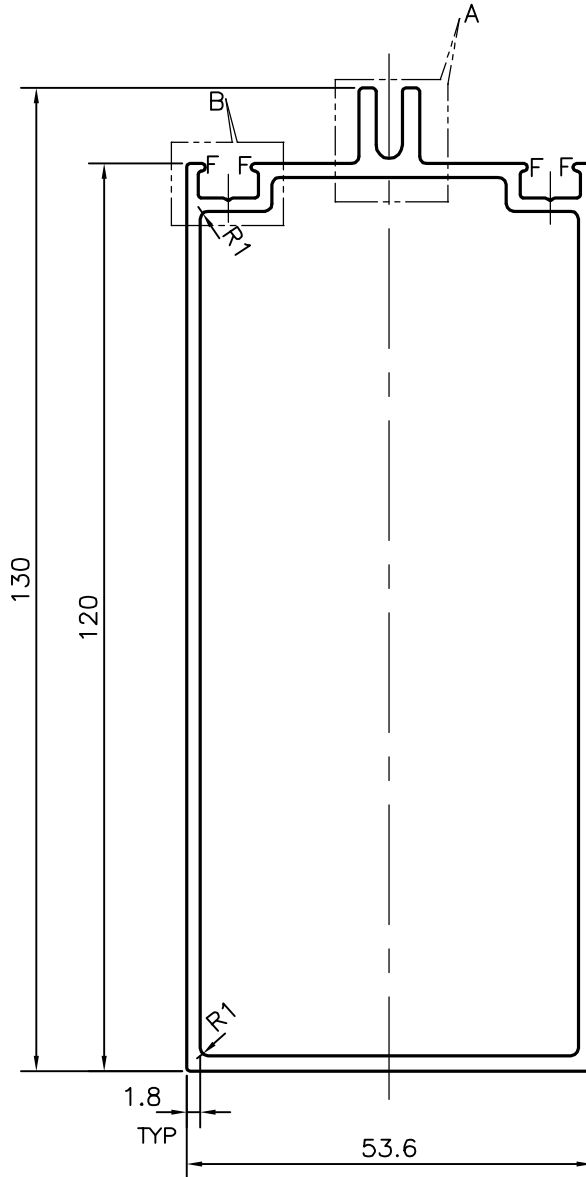
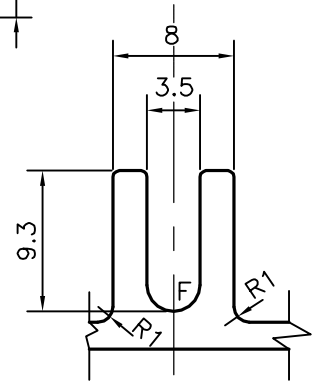

F = FULL RADIUS (5 PLACES)



SYMBOL OF QUALITY
AN ISO 9001 COMPANY

JINDAL ALUMINIUM LTD.
BANGALORE-560073 (INDIA)

	NAME	DATE
DRAWN	J.P.KAUSHIK	24-12-2016
CHECKED		
APPROVED	B.NATARAJ	22-04-2017
SCALE		1:1
AREA mm ²		688.691
PERIMETER mm.		405.598
WEIGHT kg/m		1.859
DRAWING No.	SECTION No.	
P-16660	-	
S5375	S5375	

1. ALL DIMENSIONS ARE IN mm.
2. ROUND OFF ALL SHARP CORNERS WITH 0.40 mm.
3. TOLERANCES WILL BE AS PER IS:6477-1983 UNLESS OTHERWISE SPECIFIED

PARTY'S NAME	NEW TECH INTERNATIONAL PROJECT, KOCHI
PARTY'S DRAWING No.	AS PER DRAWING
ALLOY & TEMPER	HE9 WP
DESCRIPTION	CURTAIN WALL SECTION