

P-17016

S5395

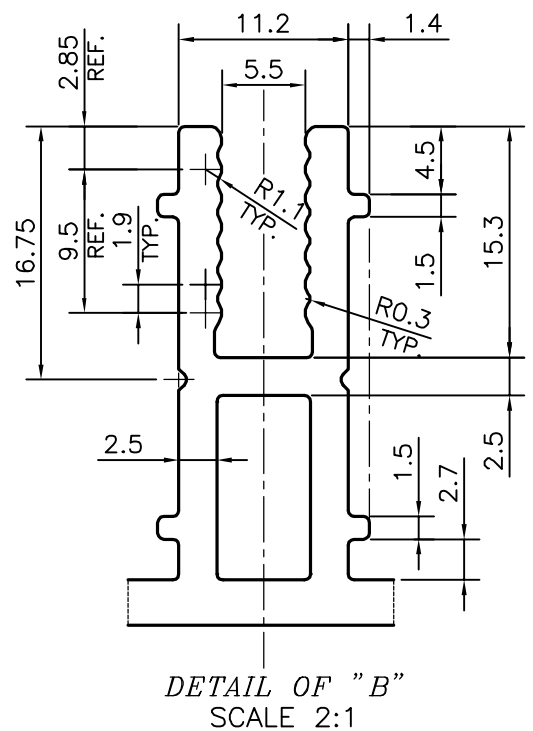

X = RADIUS 0.35 mm. (4 PLACES)

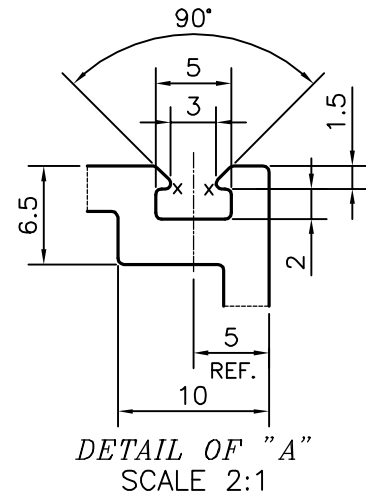
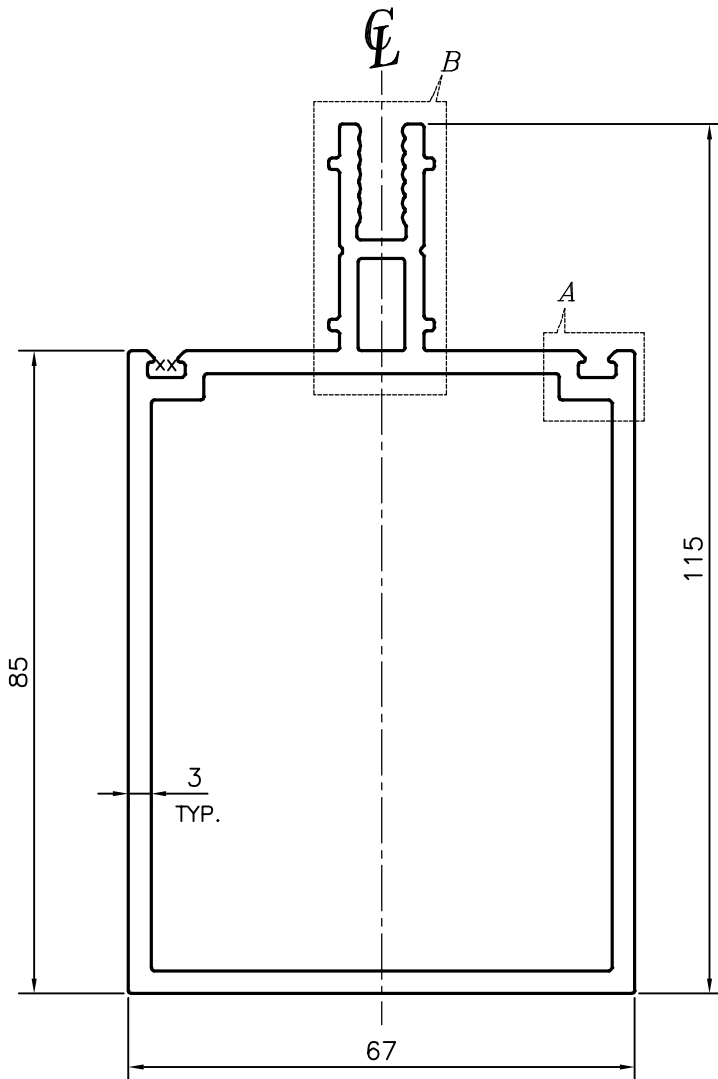

SYMBOL OF QUALITY
AN ISO 9001 COMPANY

JINDAL ALUMINIUM LTD.
BANGALORE-560073 (INDIA)

	NAME	DATE
DRAWN	PARVESH	26-04-2017
CHECKED		
APPROVED	B.NATARAJA	10-05-2017
SCALE		1:1
AREA	mm ²	1072.274
PERIMETER	mm.	422.107
WEIGHT	kg/m	2.895
DRAWING No.	SECTION No.	
P-17016	-	
S5395	S5395	

1. ALL DIMENSIONS ARE IN mm.
2. ROUND OFF ALL SHARP CORNERS WITH 0.40 mm.
3. TOLERANCES WILL BE AS PER IS:6477-1983 , UNLESS OTHERWISE SPECIFIED

PARTY'S NAME	KPC PROJECTS LTD., NOIDA
PARTY'S DRAWING No.	AS PER AUTOCAD DRAWING
ALLOY & TEMPER	6063 T6
DESCRIPTION	CURTAIN WALL SECTION-TRANSOM