

P-17267-1

S5528

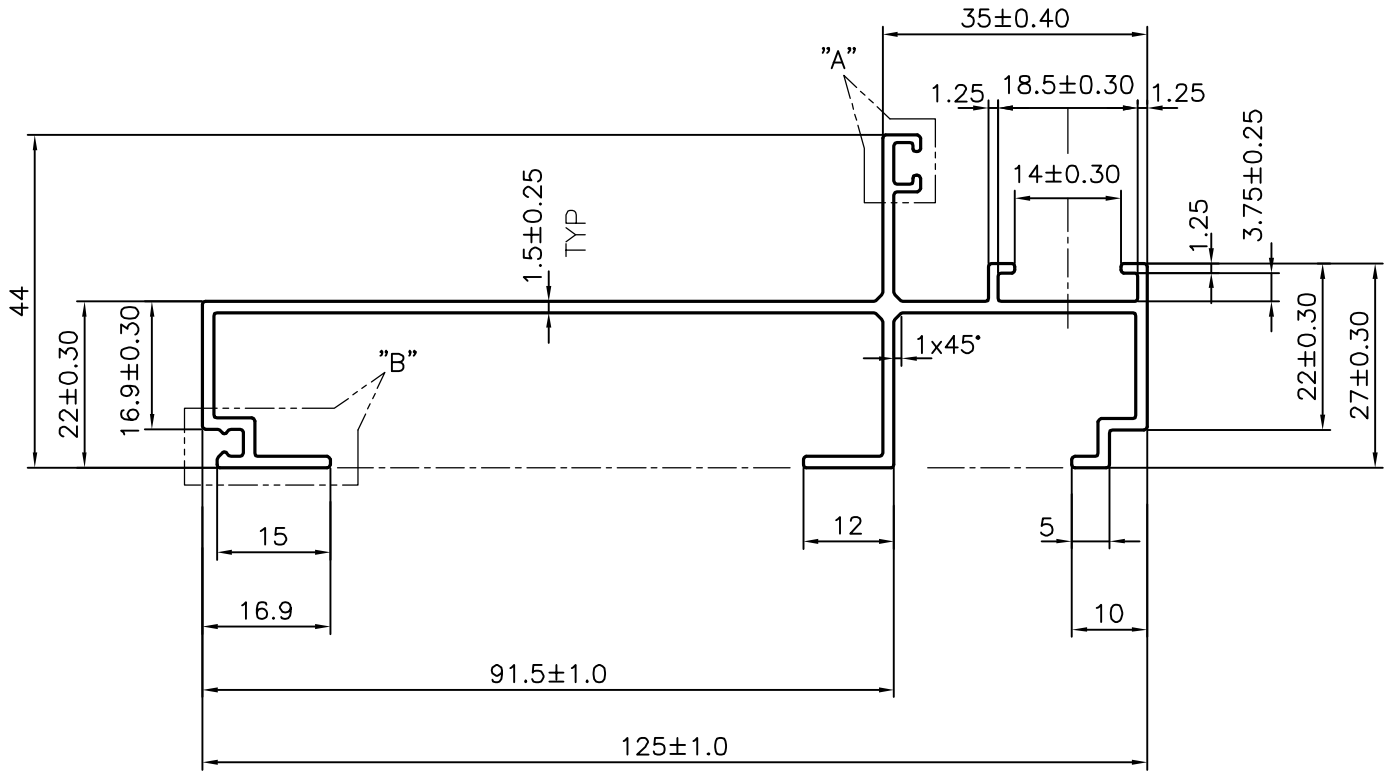
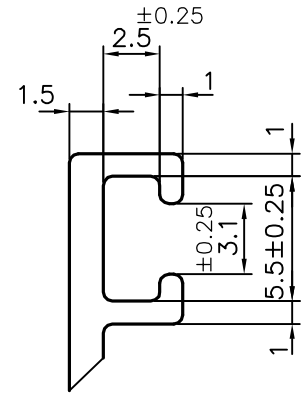
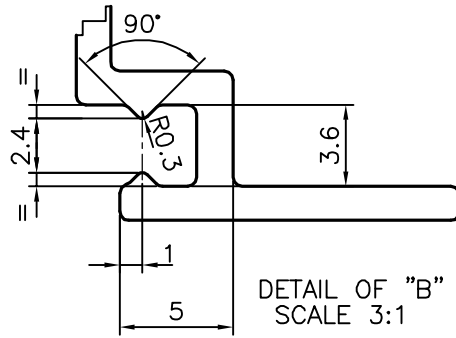

SYMBOL OF QUALITY  
AN ISO 9001 COMPANY

**JINDAL ALUMINIUM LTD.**  
BANGALORE-560073 (INDIA)

	NAME	DATE
DRAWN	J.P.KAUSHIK	28-06-2017
CHECKED		
APPROVED	B.NATARAJA	17-10-2017
SCALE		1:1
AREA mm <sup>2</sup>		399.9
PERIMETER mm.		533.777
WEIGHT kg/m		1.080
DRAWING No.	SECTION No.	
P-17267-1	-	
S5528	S5528	

1. ALL DIMENSIONS ARE IN mm.
2. ROUND OFF ALL SHARP CORNERS WITH 0.40 mm.
3. TOLERANCES WILL BE AS PER IS:3965-1981, UNLESS OTHERWISE SPECIFIED

PARTY'S NAME	AHLUWALIA CONTRACTS INDIA LTD., JHAJJAR
PARTY'S DRAWING No.	AS PER DRAWING
ALLOY & TEMPER	HE9 WP
DESCRIPTION	WINDOW SECTION