

P-17610-1

S5601

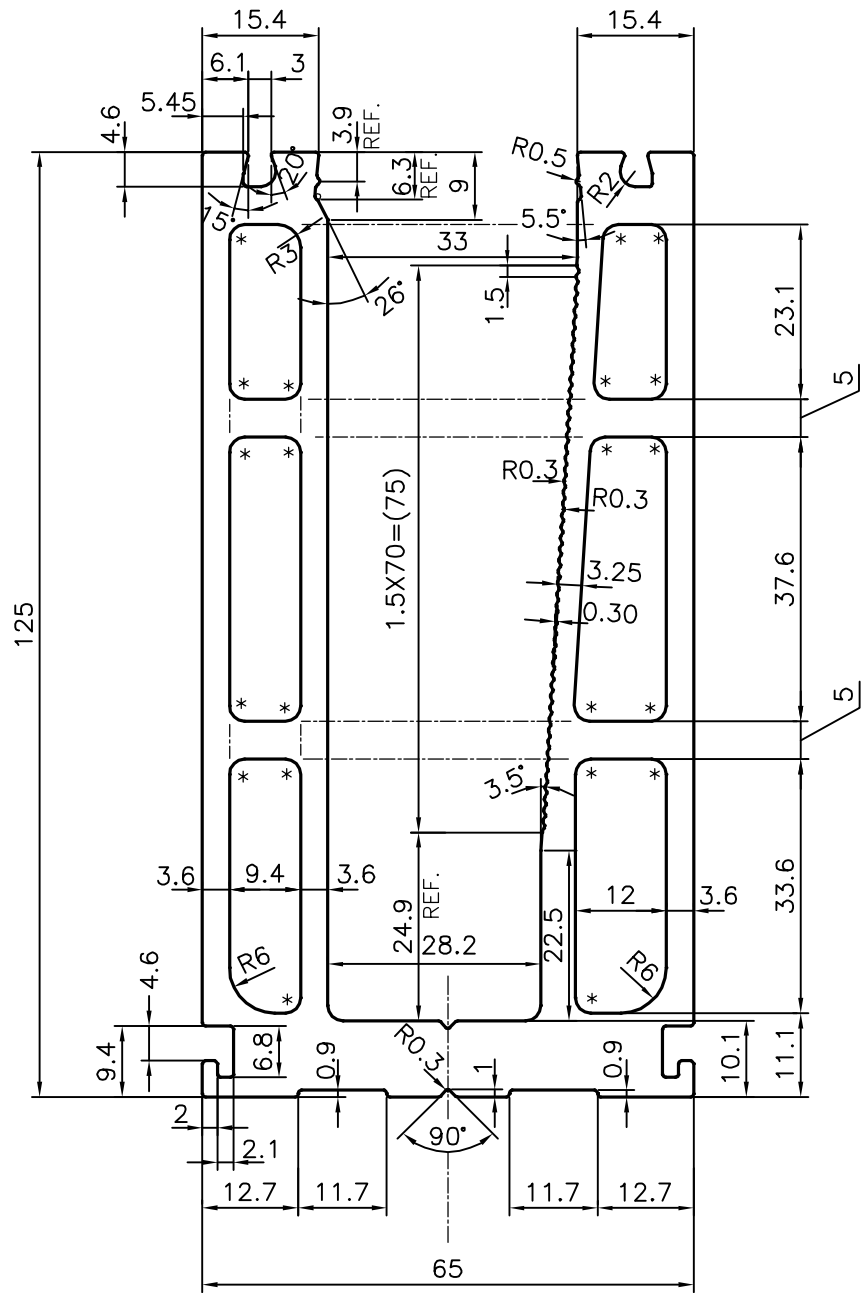

\* = 2.0 RADIUS(21 PLACES)

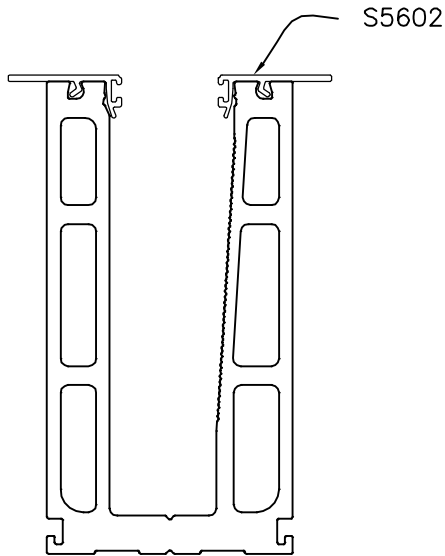

SYMBOL OF QUALITY  
AN ISO 9001 COMPANY

**JINDAL ALUMINIUM LTD.**  
BANGALORE-560073 (INDIA)

	NAME	DATE
DRAWN	J.P.KAUSHIK	18-11-2017
CHECKED		
APPROVED	B.NATARAJA	29-11-2017
SCALE		1:1
AREA mm <sup>2</sup>		2622.708
PERIMETER mm.		654.78
WEIGHT kg/m		7.081
DRAWING No.	SECTION No.	
P-17610-1	-	
S5601	S5601	

1. ALL DIMENSIONS ARE IN mm. 2. ROUND OFF ALL SHARP CORNERS WITH 0.4 mm. 3. TOLERANCES WILL BE AS PER IS:6477-1983 , UNLESS OTHERWISE SPECIFIED	
PARTY'S NAME	PANCHSHIL INFRASTRUCTURE HOLDINGS PVT. LTD., PUNE
PARTY'S DRAWING No.	AS PER AutoCAD DRAWING
ALLOY & TEMPER	6063 T6
DESCRIPTION	STRUCTURAL MISC. SECTION