

P-17810
S5649

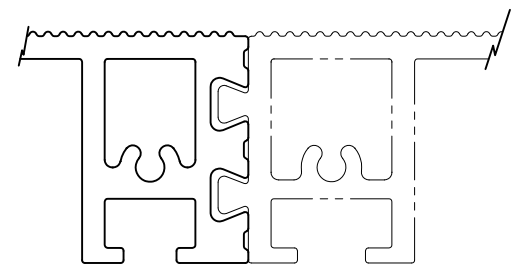

SCALE:- 1:1

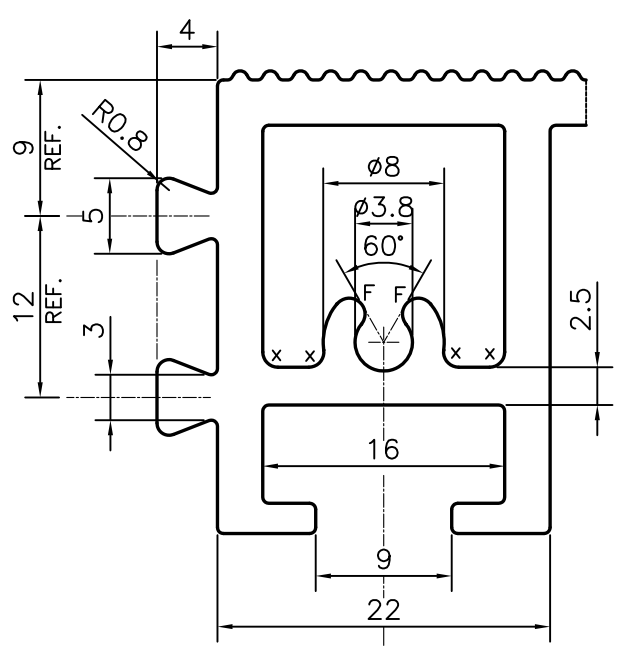
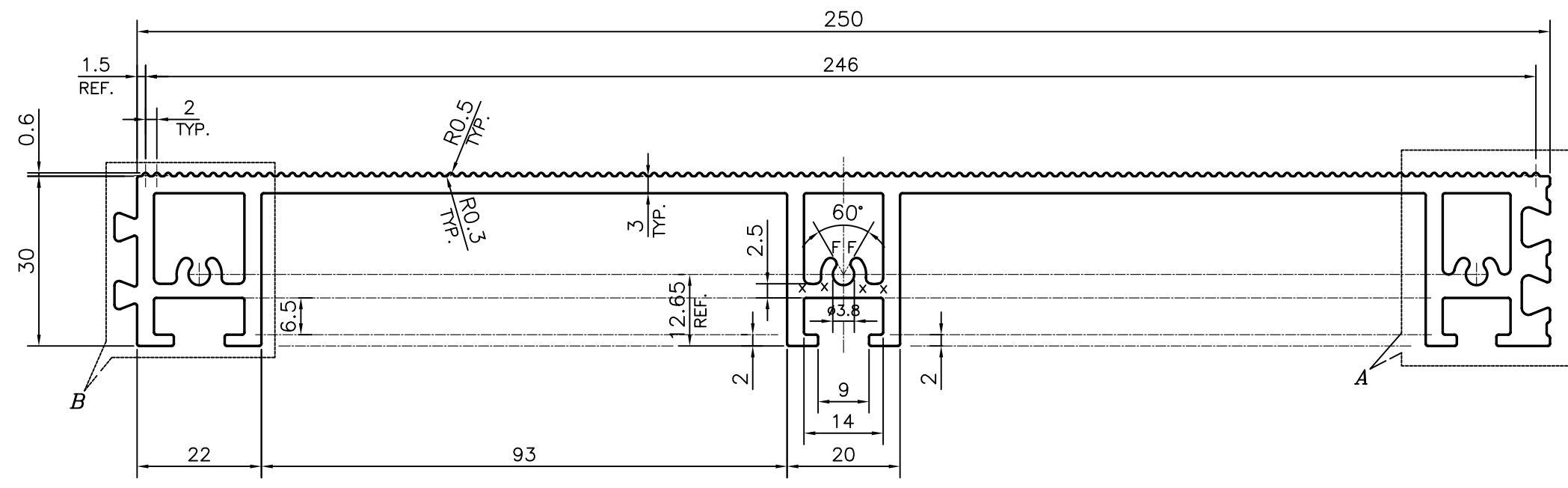

DETAIL OF "B"
SCALE 2:1

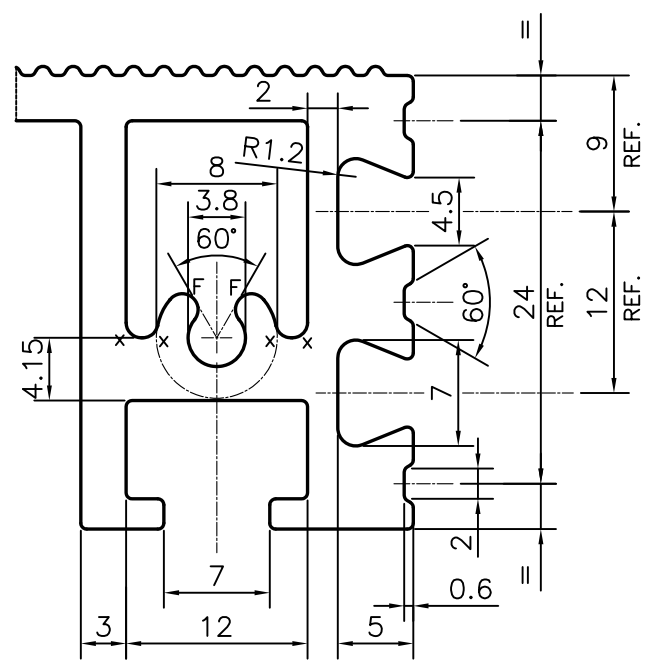

DETAIL OF "A"
SCALE 2:1

 SYMBOL OF QUALITY AN ISO 9001 COMPANY	JINDAL ALUMINIUM LTD. BANGALORE-560073 (INDIA)		NAME	DATE	
	DRAWN	PARVESH	25-01-2018		
	CHECKED				
	APPROVED	J.N.RAI	02-02-2018		
1. ALL DIMENSIONS ARE IN mm. 2. ROUND OFF ALL SHARP CORNERS WITH 0.40 mm. 3. TOLERANCES WILL BE AS PER IS:6477-1983 , UNLESS OTHERWISE SPECIFIED			SCALE	1:1	
PARTY'S NAME			WEST COAST ENGINEERING WORKS PVT. LTD., THANE	AREA mm ²	1586.412
PARTY'S DRAWING No.			AS PER DRAWING	PERIMETER mm.	854.827
ALLOY & TEMPER			6005 T6	WEIGHT kg/m	4.283
DESCRIPTION			MISC. SECTION	DRAWING No.	SECTION No.
				P-17810	-
				S5649	S5649