

P-17696

S5667

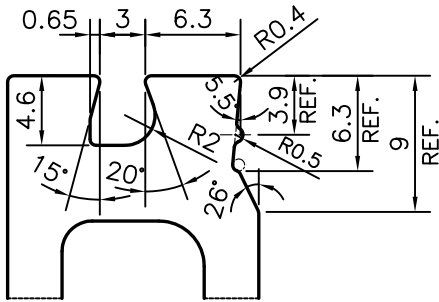
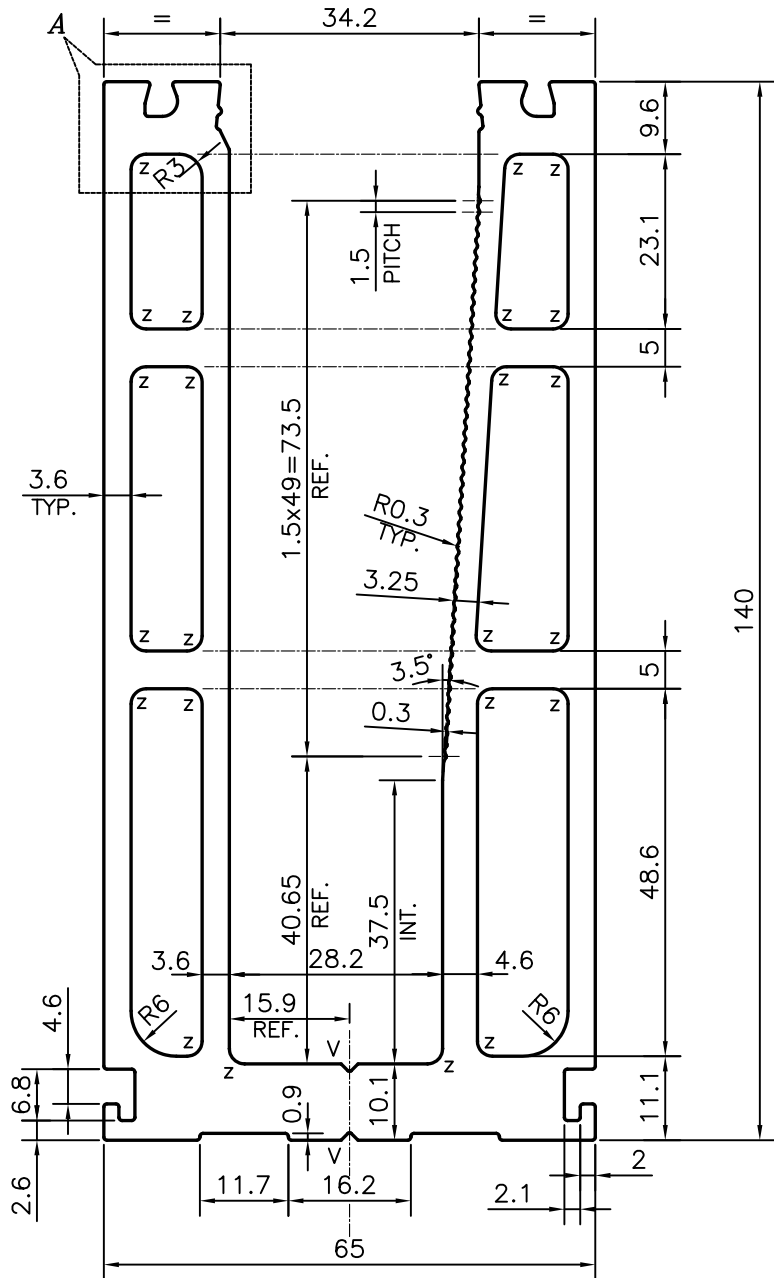
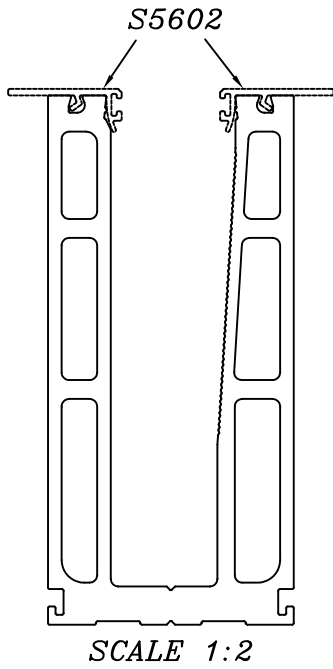

DETAIL OF "A"
SCALE 2:1

Z = RADIUS 2 mm. (23 PLACES)
V = VEE GROOVE 1x90° (2 PLACES)



SYMBOL OF QUALITY
AN ISO 9001 COMPANY

JINDAL ALUMINIUM LTD.
BANGALORE-560073 (INDIA)

	NAME	DATE
DRAWN	PARVESH	08-12-2017
CHECKED		
APPROVED	B.NATARAJA	09-02-2018

1. ALL DIMENSIONS ARE IN mm.
2. ROUND OFF ALL SHARP CORNERS WITH 0.4 mm.
3. TOLERANCES WILL BE AS PER IS:6477-1983 , UNLESS OTHERWISE SPECIFIED

SCALE	1:1
AREA mm ²	2853.722
PERIMETER mm.	714.849
WEIGHT kg/m	7.705

PARTY'S NAME	PANCHSHIL INFRASTRUCTURE HOLDINGS PVT.LTD.,PUNE
PARTY'S DRAWING No.	AS PER AUTOCAD DRAWING
ALLOY & TEMPER	6063 T6
DESCRIPTION	STRUCTURAL MISC. SECTION

DRAWING No.	SECTION No.
P-17696	-
S5667	S5667